

Technical Data Sheet

TECPRO MS741 MASTER STATION - USER GUIDE

27-741 TECPRO MS741 MASTER STATION



CONTENTS

Section 1.0	Introduction
Section 2.0	Features
Section 3.0	Installation
Section 4.0	Operation
Section 5.0	Configuration
Section 6.0	Technical Specification
Section 7.0	Wiring Convention

1.0 INTRODUCTION

The Tecpro system is a 'two-wire' or 'party line' system which enables a number of personnel to take part in the same conversation simultaneously. Major applications are in the theatre, television studios, conference venues and stadiums.

The Tecpro MS741 master station allows two intercom circuits A and B to be created and each circuit can power up to a maximum of 30 belt-packs, or a mix of belt-packs and loudspeaker stations.

System cabling should be a twisted pair with an overall screen and the cabling can radiate out from a central distribution point or looped from one outstation to the next and so on. A combination of both methods is often used.

The Tecpro MS741 is compatible with original Tecpro products.

2.0 FEATURES

- Two independent intercom circuits A and B
- Circuits A and B may be linked to form a single circuit
- Supports up to 30 Tecpro belt-packs or 7 Tecpro loudspeaker outstations per circuit
- Short circuit and overload protection on each circuit
- Built-in front panel electret microphone or XLR4 input for optional gooseneck microphone or headset
- The 'Remote Mic Kill' feature (RMK) can shut down all open mics on a selected circuit (Series 2 products only)
- The 'Override' feature can trigger an audio level change to a preset level on Tecpro LS200 and LS300 series loudspeaker outstations when sending important messages from the MS741
- AUX audio input switchable between mic or line level sensitivity for 'show relay' audio purposes
- Separate 'Announce' output allows paging announcements to be made to an external system

3.0 INSTALLATION

3.1 Power Supply

The MS741 can be rack-mounted and occupies 1U of rack space.

The unit has a universal power supply and can accept supply voltages from 90 – 260V AC. There is an IEC mains inlet provided on the rear panel. The main power switch is on the front panel and when switched on the red indicator illuminates.

3.2 Circuit A and B

Loudspeaker stations and belt-packs can be connected to circuits A or B as necessary. Two rear panel male XLR3 connectors are provided for each circuit. Please see figure 1.

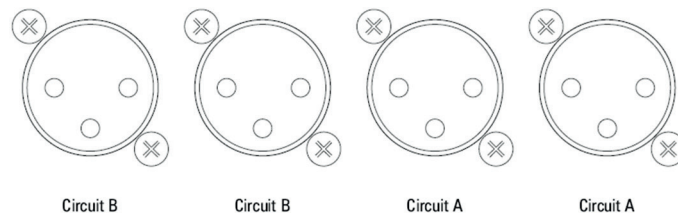

Figure 1: Rear panel XLR circuit A and B connectors

The system interconnection cable should be a screened twisted pair with XLR3 connectors as follows:

Pin 1	Earth / Screen
Pin 2	+24V DC
Pin 3	Audio

3.3 Rear Microphone Input

A rear un-balanced 2-pole 6.35mm input socket is provided to plug in a dynamic mic. N.B. Inserting a plug will mute the built-in front panel electret mic.

TIP	Signal
SLEEVE	Screen

3.4 Rear Speaker Output

A rear 2-pole 6.35mm socket is provided for an external 8R 2W speaker. N.B. Inserting a plug will mute the front panel speaker.

TIP	Signal
SLEEVE	Common

3.5 Rear Announce Output

A rear 6-pin DIN socket is provided for making an independent paging announcement to an external sound system. The audio output is electronically balanced and is at nominally line level, the relay contact closes simultaneously and can be used as a GPI contact closure to signal to external equipment.

The announce function can also be activated remotely by connecting pin 6 to pin 3

Pin 4 and 5	Balanced audio output
Pin 3	Ground
Pin 6	ANNOUNCE function. (Connect to pin 6 to pin 3 to remotely activate the function)
Pin1 and 2	Single pole relay contact, normally open

4.0 OPERATION

4.1 Circuit A and B Switches

To listen to circuit A or B first press the associated CIRCUIT switch. A momentary press will latch this function and holding the switch down will enable the function only as long as the switch is pressed. The associated circuit switch will illuminate GREEN when selected. You can then listen to all outstations and belt-packs on the selected circuits. It is possible to select A and B individually or together. Please see figure 2.

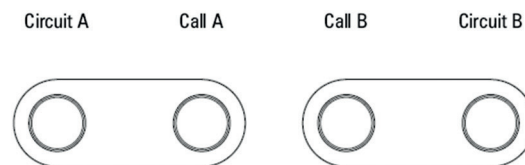

Figure 2: Circuit and call A and B switches

4.2 Speaker And Headphone Level Control

When listening to outstations and belt-packs, you can either use the front panel loudspeaker with the associated level control or plug in a Tecpro headset into the XLR4 connector and use the headphone level control. Please see figure 3.

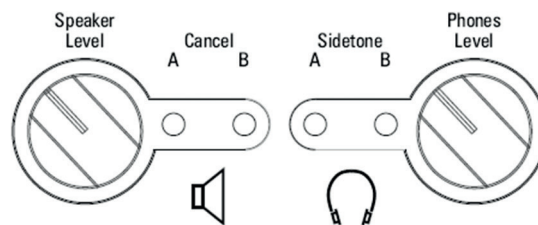

Figure 3: Loudspeaker and headphone level control

N.B. If a headset is plugged into the XLR4 connector both the front panel loudspeaker and the built-in front panel electret mic are muted.

4.3 To Communicate Using A Headset Or The Internal Mic

To communicate with other personnel on the system you can either use the built-in front panel electret microphone or alternatively you can plug in an optional Tecpro headset using the front panel XLR4 connector. An optional 27-912 Tecpro gooseneck mic is also available and this can be plugged into the XLR4 connector as a further method of talking. Please see figure 4.

Ensure the circuit you want to communicate with is first selected – please see section 4.1

Press the MIC switch to talk. A momentary press will latch this function and holding the switch down will enable the function only as long as the switch is pressed. The switch will illuminate GREEN when selected.

N.B. Connecting an optional headset will mute the front panel loudspeaker and the built-in front panel electret mic. Plugging in an optional gooseneck mic will mute the internal electret mic only.

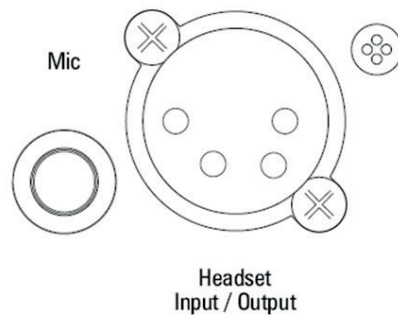

Figure 4: Front panel headset XLR4 connector, internal mic and talk switch

4.4 Rear Microphone Socket

It is possible to plug a microphone into the rear microphone socket. In this way you can talk to outstations and belt-packs on circuit A and B as selected on the front panel. N.B. Inserting a plug will mute the built-in front panel electret mic. Please see figure 5.



Figure 5: Rear mic input

4.5 Call A and B Switches

To call on circuit A or B press the associated CALL switches, please refer to figure 2. A momentary press will send a call signal for 1 second, holding the switch down will send a call signal for as long as the switch is pressed. The associated switch will illuminate RED and a call signal will be sent to all connected outstations and belt-packs on that circuit.

4.6 Remote Mic Kill

Sometimes it is necessary to kill open microphones on a circuit that are causing intelligibility problems during a show or performance. This can be achieved by pressing the remote mic kill RMK switch. It will glow RED when pressed and the associated circuit switches that are selected will flash GREEN. All open mics on the circuit selected will be killed. Please see figure 6.

N.B. This function will work with new Tecpro Series 2 products but original Tecpro products have mechanically latching mic switches and the microphone circuit cannot be killed.



Figure 6: Remote mic kill switch

4.7 Auxiliary Input

An auxiliary input is provided to allow a 'show relay' or cue audio feed to be mixed onto the Tecpro system. To control the level of auxiliary audio on the system there is a front panel AUX LEVEL control and a selector switch. A momentary press of this AUX selector switch sends the auxiliary audio to circuit A, B, or A and B together or finally turns the feature off. The associated front panel AMBER LEDs indicate the current status and the AUX switch glows GREEN to indicate auxiliary audio is being used. Please see figure 7.

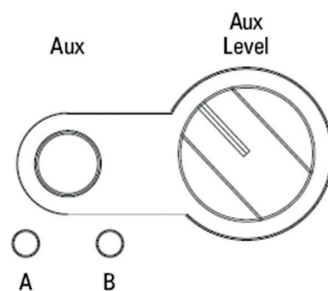

Figure 7: Auxiliary level control and channel selector

The rear balanced XLR3 auxiliary audio input is switchable between mic or line level sensitivity using the adjacent toggle switch. There are three positions: LINE, MIC and MIC with +48V phantom power. Please see figure 8

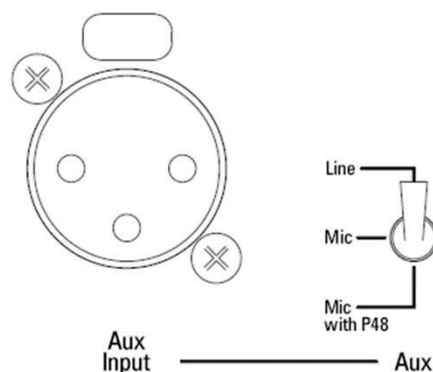

Figure 8: Rear auxiliary input XLR3

4.8 Announce Switch

To make an independent paging announcement to an external sound system press the ANNOUNCE switch. The ANNOUNCE switch will glow RED and the MIC switch will glow GREEN for the duration of the announcement. This paging announcement will only be routed to the rear 6-pin DIN socket. The audio output is electronically balanced at nominally line level and there is a single pole relay normally open contact available for GPI use. There is also the facility to remotely operate the ANNOUNCE function by closing the pin labelled Announce Switch to GND. Please see figures 9 and 10.



Figure 9: Front panel announce switch

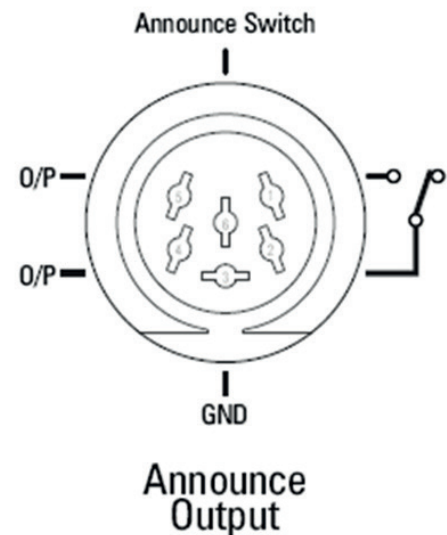

Figure 10: Rear 6-pin DIN socket

4.9 Override Switch

The override facility can be used to make an important announcement to any LS200 or LS300 series loudspeaker outstation on the system and ensures that the level of the audio on the loudspeaker is heard at a preset level – independent of the local setting of the loudspeaker volume control. To send an override voice message press the OVERRIDE switch. The OVERRIDE switch will glow RED and the MIC switch will glow GREEN for the duration of the message. Also, the circuits that are selected will flash GREEN on the front panel. Please see figure 11.



Figure 11: Front panel override switch

4.10 Channel A and B Overload Indicator LED

The front panel channel overload indicators will glow if the respective channel has a system cable 'short circuit' or if it is overloaded with too many outstations. Channel A and B have individual indicators.

N.B. This is a fault condition and should be investigated to find the cause.

Once the fault has been cleared in the system, the MS741 will automatically restore the system 24V and the respective LED will go out. Please see figure 12.



Figure 12: Overload And Termination Off LED Indicators

4.11 Channel Linking

You can link circuits A and B together using a front panel toggle switch to form a single circuit. In the 'LINK B TO A' position all personnel on circuits A and B will be able to communicate with each other. In the 'CIRCUITS INDEPENDENT' position circuits A and B are separate. Please see figure 13.

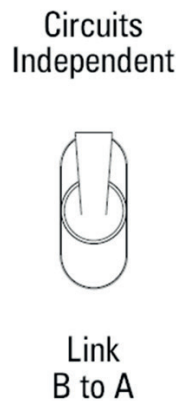

Figure 13: Circuits independent or linked toggle switch

5.0 CONFIGURATION

N.B. Please note that these adjustments are for advanced users only and the factory default settings are the preferred option for most users - and so no adjustments would normally be required.

Adjustments are made by positioning handbag links on PCB headers and adjusting variable potentiometers. Please see figure 14 for their locations.

ADJUSTMENTS SHOULD ONLY BE MADE BY SUITABLY QUALIFIED PERSONNEL.

5.1 Cancel and Sidetone Presets

These are accessible through the front panel. N.B. They will not normally require adjustment as they have been carefully set for a null position during manufacture.

The function of the CANCEL preset is to minimise acoustic feedback between the front panel electret microphone and the front panel speaker. There are individual CANCEL presets for circuit A and B.

The function of the SIDETONE preset is to minimise the amount of microphone signal heard in the headset when plugged in. There are individual SIDETONE presets for circuit A and B.

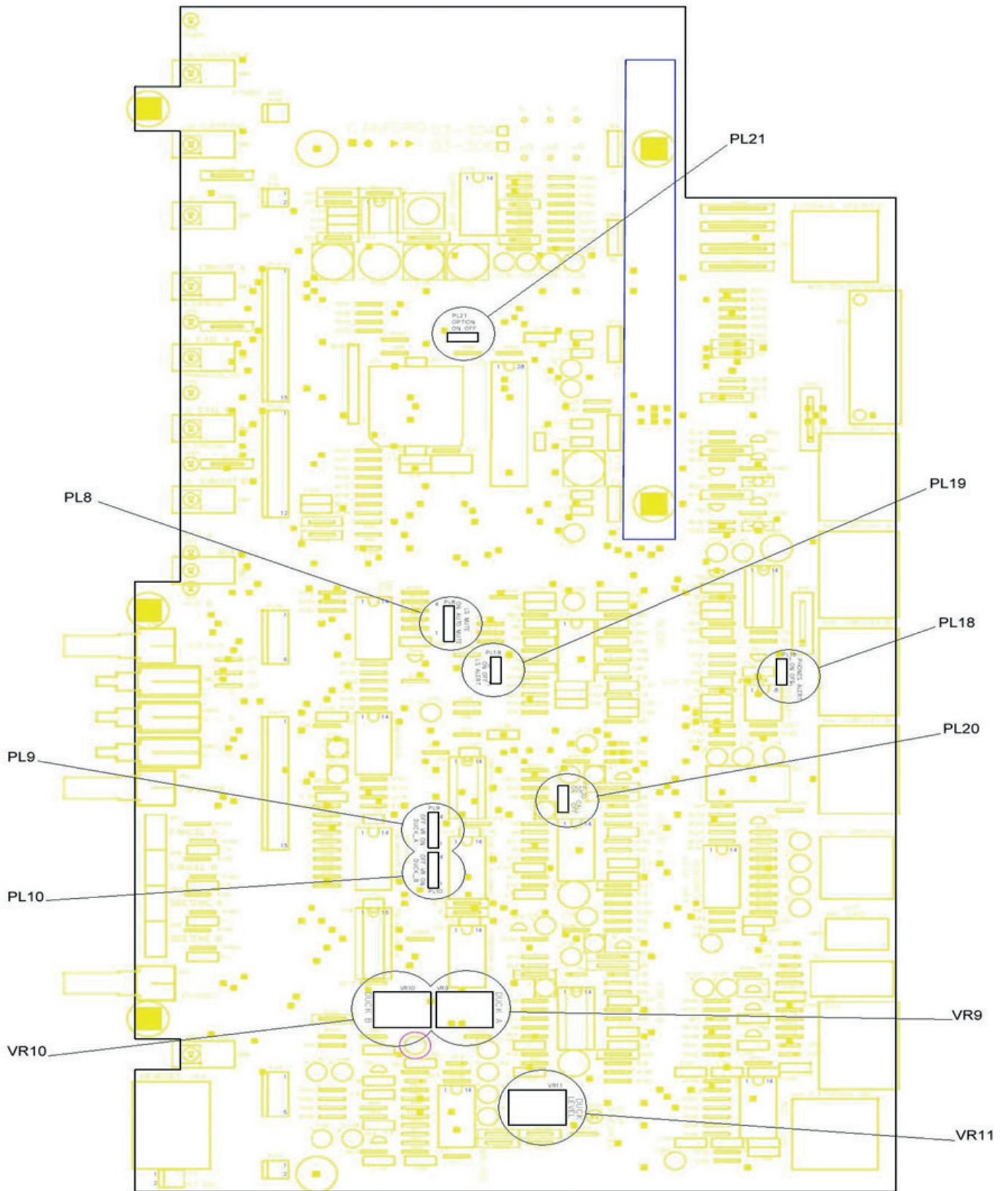

Figure 14: Internal View Of MS741 Main PCB layout

5.2 Internal View Of Main PCB

IMPORTANT - Before removing the top cover, please make sure the unit is un-plugged from the mains supply. Remove the seven top cover screws and slid the cover off. This will reveal the main internal PCB. Please see figure 14.

5.3 Internal Loudspeaker Mute

The LS MUTE header PL8 has three link positions:

- ON The internal loudspeaker is always on, the headphone is muted.
- AUTO The internal loudspeaker will mute when a headset is plugged into the XLR4 connector.
- MUTE The internal speaker is always muted, the headphone signal is on.

The factory default setting is AUTO - please see figure 15

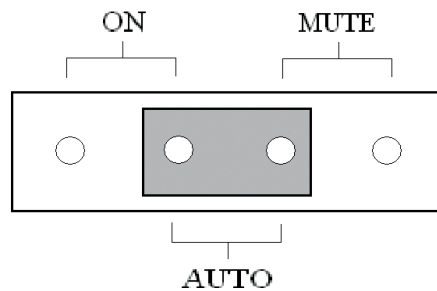

Figure 15: LS MUTE PL8

5.4 Ducking Threshold

When a microphone signal from the MS741 exceeds the threshold level set by preset VR11 it illuminates the internal LED D10 and reduces the level of the auxiliary signal present on circuit A and B.

N.B. The threshold level of VR11 is set during manufacture and should not need further re-adjustment.

5.5 Ducking Of Auxiliary Audio

The DUCK_A header PL9 has three link positions:

- OFF The auxiliary audio level on circuit A is muted during the presence of a microphone signal from the MS741 on circuit A.
- VR The auxiliary audio level on circuit A is reduced by a level preset by VR9 – set during manufacture to give 12 dB ducking of the auxiliary audio.
- ON The auxiliary audio level on circuit A is unaffected by the presence of a microphone signal from the MS741 on circuit A.

The factory default setting is VR - please see figure 16.

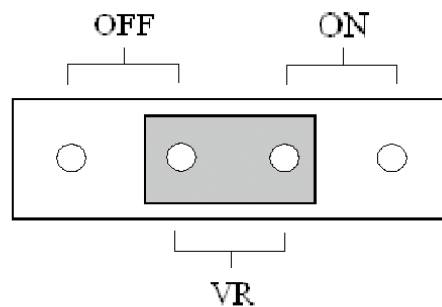

Figure 16: DUCK_A PL9

N.B. The DUCK_B header PL10 has the same functionality but controls the auxiliary audio signal on circuit B. VR10 sets the level of ducking.

5.6 Loudspeaker Alert

The LS ALERT header PL19 has two link positions:

- ON When any function switch is selected a short 'beep' tone is audible at a low level on the internal loudspeaker. Also, a longer 'beep' sounds when any outstation calls – this is not affected by the front panel loudspeaker volume control setting.
- OFF No 'beep' tones are audible

The factory default setting is ON - please see figure 17.

5.7 Headphones Alert

The PHONES ALERT header PL18 has two link positions:

- ON When any function switch is selected a short 'beep' tone is audible at a low level on the XLR4 headset circuit. Also, a longer 'beep' sounds when any outstation calls – this is not affected by the front panel phones volume control setting.
- OFF No 'beep' tones are audible.

The factory default setting is ON - please see figure 18.

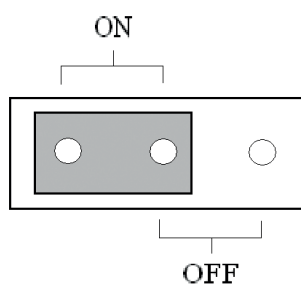
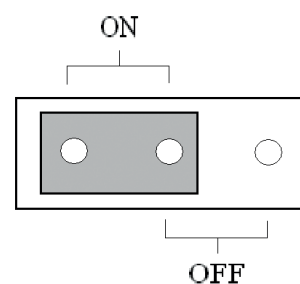

Figure 17: LS ALERT PL19 Figure



18: PHONES ALERT PL18

5.8 DC Call Option

The DC CALL header PL20 has two link positions:

- ON When a call signal is sent onto any circuit from the MS741 a DC voltage is sent. This is necessary to ensure compatibility with existing circuits that use original Tecpro outstations.
- OFF Can only be used when a system consists entirely of new Series 2 Tecpro outstations which use 20kHz call signalling.

The factory default setting is ON - please see figure 19.

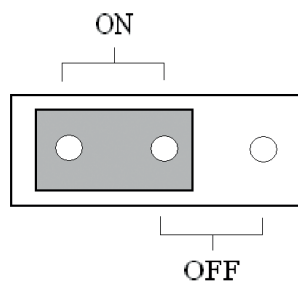

Figure 19: DC CALL PL20

5.9 Option PL21

PL21 is not currently used. Set to OFF.

5.10 Termination Off

In some systems there may be a requirement to convert the MS741 to be a simple outstation - that no longer acts as a master. This would be the case if a master station already existed on the system. To accomplish this, link pin 8 to 15 on the rear 15-pin D Sub connector. Do this in an external mating connector Canford product code 44-012 (15 pin D Sub male) and 44-015 (Metal hood). This will then disable the network termination impedance on circuit A and B. The front panel TERMINATION OFF LED will now illuminate RED. Please see figures 12 and 20.

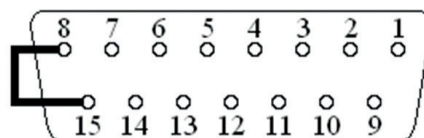

Figure 20: Mating 15-pin D Sub male cable connector, rear solder side view, showing link

N.B. It is important a master station exists on circuits A and B otherwise very poor quality audio communication will result.

6.0 TECHNICAL SPECIFICATION

Microphone	200 ohm dynamic type
Headset earphone	400 ohm typical – 32 ohm to 4k ohm acceptable
Front panel built-in mic	Electret type
Internal speaker	2W elliptical type
Rear speaker output	2-pole A-gauge 6.35mm socket for an 8R 2W speaker
System output voltage	+24V DC
System line termination impedance	200 ohm in the audio frequency band, 5k ohm at DC
Auxiliary Input	XLR3 electronically balanced, line or mic sensitivity with +48V phantom power
Rear microphone Input	2-pole A-gauge 6.35mm unbalanced socket
Announce output	6-pole DIN socket with electronically balanced audio output. Single pole relay contact rated at 30V 1A maximum for GPI use
Call signal	DC and 20kHz
Remote mic kill signal (RMK)	24kHz
Override signal	28kHz
Maximum number of outstations per circuit	30 beltpacks or 7 loudspeaker stations
System cabling	Fixed installations: 31-050 FST-HD Mobile facilities: 30-130 HST-HD
Power	90 – 260V AC 50 – 60Hz
Fuse rating	2A (T) HBC for 240V AC operation 4A (T) HBC for 110V AC operation
Dimensions	1U rack mount 195mm deep
Weight	1.6 kilos

7.0 WIRING CONVENTION

7.1 Cable requirements

Three factors affect the choice of cable for a particular system or installation:

- The length of cable run – longer runs require a larger gauge cable.
- The number of outstations on each cable – increasing the number of outstations requires a larger gauge cable.
- Permanent installation or mobile use.

In general, we suggest a screened 0.5 sq mm (20AWG) twisted pair cable should be used. Canford heavy duty cables FST-HD, HST-HD and HST-HD-R are suitable. HST-HD-R has a polyurethane jacket, which has very similar properties to rubber – i.e. very abrasion resistant and resilient. FST-HD is a foil screened cable specifically for permanent installation purposes. HST-HD can be used for mobile systems.

7.2 System cable connectors for current beltpacks

BP511, BP531, BP523, BP543	XLR3	Pin 1	Earth / Screen
		Pin 2	+24V DC
		Pin 3	Audio
BP525, BP545,	XLR5	Pin 1	Earth / Screen
		Pin 2	+24V DC
		Pin 3	Audio Circuit 1
		Pin 4	+24V DC
		Pin 5	Audio Circuit 3

N.B. XLR5 pin connectors must be Neutrik type. Switchcraft XLR5 pin types are non-standard - and are NOT suitable.

7.3 Headset connectors for current beltpacks

XLR4 4pin	Pin 1	Microphone screen
	Pin 2	Microphone signal
	Pin 3	Earphones common
	Pin 4	Earphones signal

7.4 System cable connectors for current beltpacks

BP111, BP112, BP114, BP116	XLR3	Pin 1	Earth / Screen
		Pin 2	+24V DC
		Pin 3	Audio
BP113, BP115, BP117	XLR6	Pin 1	Earth/screen
		Pin 2	+24V DC
		Pin 3	Audio Circuit 1
		Pin 4	Audio Circuit 2
		Pin 5	Audio Circuit 3
		Pin 6	Audio Circuit 4

7.5 Headset connectors for older beltpacks

BP111, BP112, BP113, BP114, BP115	XLR4	Pin 1	Microphone screen
		Pin 2	Microphone signal
		Pin 3	Earphones common
		Pin 4	Earphones signal
BP116, BP117	XLR5	Pin 1	Microphone screen
		Pin 2	Microphone signal
		Pin 3	Earphones common
		Pin 4	Left earphone
		Pin 5	Right earphone



For more information on products and services, please contact our sales team:

UK Sales 0191 418 1122 sales@canford.co.uk

International Sales +44 (0)191 418 1133 international@canford.co.uk

canford.co.uk