

Digital Wireless Transmitter

Operating Instructions

DWT-B30

DWX **WiDIF-HP**
DIGITAL WIRELESS  Cross Remote

Table of Contents

Features	3
Parts Identification	4
Power Supply	5
Installing the batteries	5
Setting the Transmission Channel	6
Selecting the group/channel	6
Using Cross Remote	7
Pairing with a receiver	7
Using the Encrypted Transmission Function	8
Using the encryption key modes (SECURE KEY / AES256)	8
Using the password mode (PASSWORD)	9
Basic Menu Operations	9
Setting Menus	10
Unit name setting (NAME)	10
Selecting the frequency band (BAND)	10
Selecting the group/channel (GP/CH)	10
Audio attenuator setting (AF ATT)	10
Low-cut filter setting (LCF)	10
Lock function (LOCK)	11
Power save setting (POWER SAVE)	11
Setting the battery type (BATTERY TYPE)	11
Cross Remote (RF REMOTE)	11
Receiver search function (SEARCH RX)	11
Audio codec mode setting (CODEC MODE)	12
Encrypted transmission function Setting (ENCRYPTION)	12
Audio input level setting (INPUT LEVEL)	12
Audio phase switch function (AF PHASE)	12
Generating an internal signal (INTERNAL SG)	12
Setting the RF output power (RF POWER)	12
Setting the maximum RF output power (MAX RF POWER)	13
Displaying the accumulated use time (TIME)	13
Setting the brightness of the display (BRIGHTNESS)	13
Automatic dimming of the display (DIMMER MODE)	13
Settings storage function (USER MEMORY)	13
Power source priority setting (POWER PRIORITY)	14
Resetting parameters to their factory settings (FACTORY PRESET)	14
Displaying the software version (VERSION)	14
Attaching With the Soft Case	14
Changing the direction of the belt clip	14
Wrapping the microphone cable around the soft case	14
Removing the unit from a belt	15
Block Diagram	16
Troubleshooting	17
Important Notes on Operation	18
Notes on using the transmitter	18
On cleaning	18

Notes on simultaneous multi-channel operation	18
Note on microphone and transmitter combinations	18
CROSS REMOTE Compatibility	18
Specifications	19
Carrier Frequencies and Channel Steps	20

Features

The DWT-B30 is a digital wireless transmitter for a UHF synthesized wireless microphone system to be used for broadcast or movie production purpose. This transmitter is suitable for Electronic News Gathering (ENG) and Electronic Field Production (EFP).

What is DWX?

DWX refers to Sony's new digital wireless microphone system. The DWX series reflects Sony's extensive expertise in professional microphones and sound design. It represents a successful blend of Sony know-how, wireless technology renowned for stability, and cutting-edge digital audio technology.

In addition to realizing the high sound quality possible with a digital system, the DWX series supports multi-channel simultaneous operation, encrypted transmission, and metadata transmission for monitoring the status of multiple transmitters. Using a main link and a separate additional link, remote control of transmitters from the receiver is also possible. With its many advanced features, the system has the potential to revolutionize the workflow of professional applications.

What is WiDIF-HP?

WiDIF-HP (WiDIF: Wireless Digital Interface Format, HP: High Profile) is a wireless digital audio interface format developed by Sony. It enables highly secure transmission with high sound quality and low system latency, and supports simultaneous multi-channel operation.

What is Cross Remote?

Cross Remote is a system that allows transmitters to be monitored and controlled from a receiver and the Wireless Studio control software installed on a computer connected to the receiver.

For example, the settings of a transmitter worn under clothing can be easily changed over the wireless link.

Simultaneous multi-channel operation

Simultaneous multi-channel operation is made possible with the 375-kHz interval channel plan.

High sound quality and low latency

Low system latency of 1.2 ms (minimum) is achieved when using CODEC MODE2.

Switch between four audio codec modes based on your operational needs.

For details, see "Audio codec mode setting (CODEC MODE)" (page 12).

Encrypted transmissions

AES 256-bit encryption allows for highly secure wireless transmissions.

Switchable mic or line input level and adjustable attenuator

Supports line/mic input and is equipped with an audio attenuator that is adjustable in 3 dB steps up to a maximum of 48 dB during mic input. The attenuator can be controlled remotely from the receiver.

RF transmission output switching available

RF transmission output can be set to 2, 10, or 25 mW according to multi channel operation or long-distance transmission priority.

For details, see "Setting the RF output power (RF POWER)" (page 12).

User-set memory function

Various settings can be saved and activated on the transmitter.

For further details, see "Settings storage function (USER MEMORY)" (page 13).

USB for external power supply

An external supply enables operation for long periods of time and power supply in emergencies.

Compact, lightweight, and rugged design

The unit is equipped with a magnesium-alloy casing, providing a body that is durable in addition to being compact and lightweight.

Supports operation for long periods of time and various battery types

The DWT-B30 supports various battery types, such as AA alkaline batteries, lithium ion batteries, and NiMH batteries. It can be operated for approximately 6.5 hours when powered by alkaline batteries.

Organic EL (electroluminescent) display

The quick response of the OLED (organic light-emitting diode) display enables real-time operating conditions to be displayed clearly and accurately.

Parts Identification

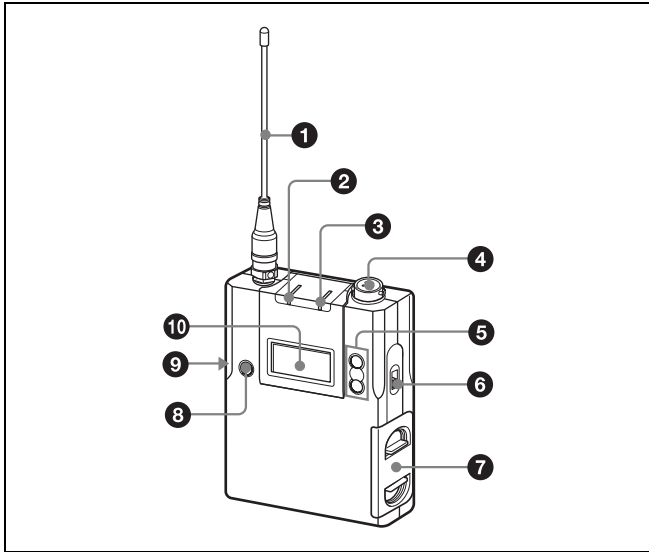

1 Antenna

2 AF (audio input level) /PEAK indicator

Lights up green when the signal input is stronger than the reference level.

Lights up red when the signal input is 3 dB below the level at which distortion begins.

3 POWER indicator

Lights up green when the transmitter is turned on. When the battery is exhausted, the indicator starts flashing.

4 Audio input connector

Connects the output plug from the optional lavalier microphone.

This connector also accepts the input from another wired microphone connected through the supplied microphone cable, or the audio output from a mixer, etc.

US model

Connector front view

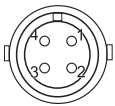

- 1: DC output + 5.2 V (for lavalier microphone power supply)
- 2: HOT (input impedance 4.7 kohms or more)
- 3: COLD (input impedance 4.7 kohms or more)
- 4: GND

To connect a microphone

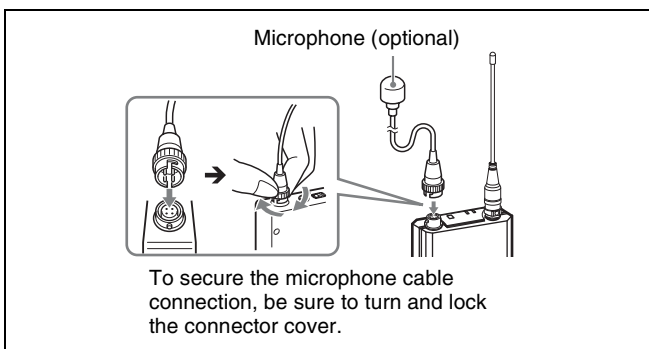

European model

Connector front view

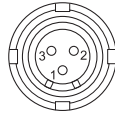

- 1: GND
- 2: +5.2 V DC output (for power supply of lavalier microphone)
- 3: HOT (input impedance 4.7 kohms or more with +5.2 V DC)

Connecting the microphone

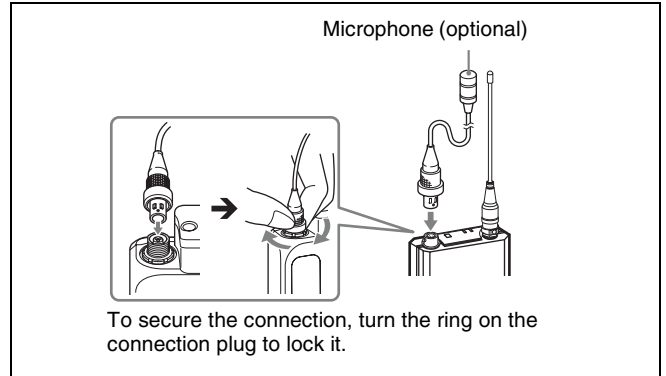

5 + or - button

Selects functions or values shown on the display. Holding down the - button while switching on the transmitter activates the pairing operation for the wireless remote control function.

6 POWER switch

Turns the transmitter ON or OFF.

7 Battery compartment

Accommodates two LR6 (size AA) alkaline batteries.

For details on how to insert the batteries, see "Power Supply" (page 5).

8 SET button

Adjusts displayed function settings and enters the value. Holding down the SET button while switching on the power turns the transmitter on without sending a signal.

9 USB connector (Micro USB)

The transmitter can be operated for long periods of time using a mobile battery or commercial USB power source.

10 Display section

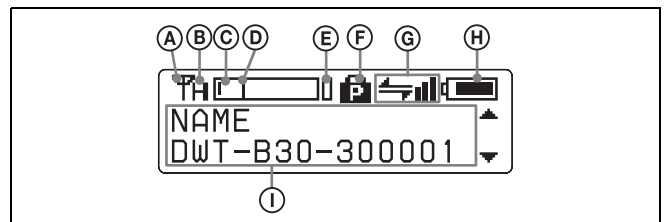

A RF transmission indication

Indicates the current transmission status.

☐: Currently transmitting

—: Transmission stopped

Ⓑ RF (radio frequency) transmission power indication

Indicates the current transmission power setting. You can change the setting with the RF transmission power setting function.

H: transmitting at 25 mW

M: transmitting at 10 mW

L: transmitting at 2 mW

Ⓒ Audio input level meter

Indicates the input signal level.

Ⓓ Reference level gauge

Indicates the reference input level. When the attenuation is 0 dB with INPUT LEVEL set to MIC, -58 dBu (-60 dBV) is indicated. When LINE is selected for INPUT LEVEL, +4 dBu is indicated.

Ⓔ Peak indicator

Warns of excessive input by lighting up when the signal is 3 dB below the level at which distortion begins.

Ⓕ Lock indicator

Indicates whether the accidental operation locks are enabled. Nothing is displayed when the lock function is disabled.

: Operation of the POWER button is locked.

: Changes to the settings are locked.

: Operation of the POWER button and changes to the settings are locked.

For details, see “Lock function (LOCK)” (page 11).

Ⓖ Cross Remote condition indication

Indicates the signal transmission condition of the wireless remote control function (4 levels).

: Good transmission

: Somewhat good transmission

: Somewhat poor transmission

: Poor transmission

: Unable to communicate with paired receiver

When the wireless remote control function is off, this indication does not appear.

Ⓗ Power display

Displays the type of power source being used.

: Operating on battery power, displays remaining battery level.

: Operating on USB power.

For details, see “Battery indication” (page 5).

Ⓘ Menu display section

The status of 17 different functions are displayed here. To select the function, press the + or - button repeatedly.

For details, see “Setting Menus” (page 10).

Power Supply

The transmitter can operate on two LR6 (size AA) alkaline batteries continuously for about 6.5 hours at 25 °C (77 °F). Connecting a mobile battery to the USB connector enables operation for a long period of time.

Installing the batteries

- 1 Squeeze the battery-holder tabs inward (in the direction of the arrows) and slide out the battery holder.

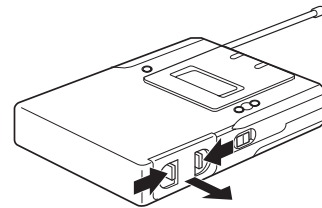

- 2 Insert new batteries, making sure the polarities are correct, and then return the battery holder to its original position.

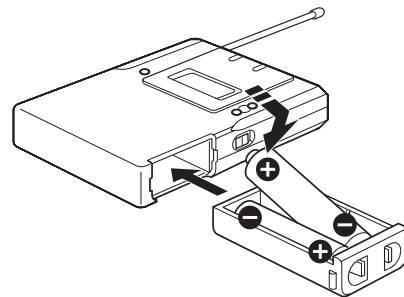

Battery indication

The power status is indicated by eight level indications. Replace both batteries when the battery indication starts to flash.

Be sure to check the expiration date printed date on the new batteries before using them.

Notes

- When BATTERY TYPE is set to TYPE1, the power status is indicated based on the use of new LR6 (size AA) Sony Alkaline batteries. An incorrect indication may result when a different kind of batteries, a different brand of batteries or old batteries are used. If you plan to use other kind of batteries than alkaline, set the BATTERY TYPE function according to the type of batteries to be used.
- If you plan to use the transmitter for a long period of time, it is recommended that you replace the batteries with brand new ones.
- Use USB power source capable of supplying 1.0 A or higher.

- Operation is not guaranteed on all USB power sources. Make sure to test the power source before using it.
- The transmitter cannot be used when connected to a USB device that possesses communication functions, such as a computer.

For details on BATTERY TYPE setting, see “Setting the battery type (BATTERY TYPE)” (page 11).

Setting the Transmission Channel

The transmitter provides groups of interference-free channels. When using multiple microphones and transmitters at the same time (simultaneous multi-channel operations) within the same area, selecting the same group and using a channel within that group can prevent signal interference.

To set the transmission channel on the transmitter, first you select the group and channel using the RF indicator and scanning functions on the receiver. Next you set the group and channel parameters to match the setting on the receiver.

Notes

- Certain transmission channels cannot be used with the wireless remote control function.
For details on transmission channels that do not support the wireless remote control function, refer to the frequency lists.
- When selecting the channel, “(INCOMPATIBLE WITH RF REMOTE)” will slide across the display for transmission channels that cannot be used with the wireless remote control function.
- When a transmission channel that cannot be used with the wireless remote control function is selected, “RESTRICTED BY GP/CH SETTING” appears on the RF REMOTE screen and the wireless remote control function cannot be used. To enable use of the wireless remote control function, select transmission channels for which “(INCOMPATIBLE WITH RF REMOTE)” does not appear during channel selection.

Selecting the group/channel

Notes

- Before doing this procedure, use the BAND function (*see page 10*) to set the transmitter to the bandwidth of the receiver you are using.
- The setting for this function cannot be changed during actual signal transmission.

Set the transmitter group (GP) and channel (CH) as follows:

For details on groups and channels included in each frequency band, refer to the frequency lists.

For details on menu operation, see “Basic Menu Operations” (page 9).

- 1** Turn off the power, and then while holding down the SET button, turn the power on.

The signal transmission stops.

- 2 Press the + or – button repeatedly until the GP/CH indication is displayed.
- 3 Hold down the SET button until the item to be set flashes.
- 4 Press the + or – button repeatedly to select a group.
- 5 Press the SET button to enter the group.
The channel indication starts flashing.
- 6 Press the + or – button repeatedly to select a channel.
- 7 Press the SET button to enter the channel.

Note

To start signal transmission with the selected channel, turn off the power and then turn it on again.

To set the group/channel using the pairing mode of the Cross Remote

When the transmitter is paired with the receiver, the transmission channel of the transmitter is set to the receiving channel on the receiver automatically.

For details, see “Pairing with a receiver” (page 7).

Using Cross Remote

This transmitter is equipped with a wireless remote control function that can be used to set the parameters (low-cut filter, attenuation operation, power save mode, etc.) of the transmitter through the receiver or other devices. This function makes it easier to operate and manage the microphone system while in the field.

This wireless control is 2.4 GHz IEEE802.15.4 compliant and has no effect on the RF band of digital wireless audio. This function is activated when pairing is established between the transmitter and the receiver using the RF REMOTE function.

Pairing must be done first before the wireless remote control function can be used.

Note

If “RESTRICTED BY GP/CH SETTING” appears on the RF REMOTE screen, the wireless remote control function cannot be used. To use the wireless remote control function, select a different transmission channel.

For details on how to change the transmission channel, see “Setting the Transmission Channel” (page 6).

Pairing with a receiver

Pairing links the transmitter with the receiver which the wireless remote control function is to be used.

When the transmitter has been paired with a receiver through the receiver operation, turning on the transmitter while holding down the – button establishes the pairing immediately.

To carry out pairing through menu operations on the transmitter, do the following.

- 1 Set the receiver to be used for controlling the transmitter to pairing mode.

For details, refer to the operating instructions supplied with the receiver.
- 2 Press the + or – button repeatedly until the RF REMOTE indication is displayed.
- 3 Hold down the SET button until the item to be set flashes.
- 4 Press the + or – button repeatedly to select PAIRING.
- 5 Press the SET button to enter.

The transmitter sends a pairing request to the receiver which is on pairing mode.

Before established pairing, if you press any operation key on the transmitter, pairing mode will be cancelled. When pairing has been established, the wireless remote control condition level (indicated by )

goes up, RF REMOTE turns on, and the remote control function becomes operative.

To use the Cross Remote with a previous pairing

In the RF REMOTE indication, select ON.

Notes

- When you set RF REMOTE to ON, the transmitter will communicate with the receiver to which it was previously paired. To use the wireless remote control function with another receiver, you must perform the pairing procedure for that receiver.
- Multiple transmitters cannot be paired with the same receiver.
- If you reset all parameters by using the FACTORY PRESET function (see page 14), the pairing setting of the transmitter is also cleared.

The following transmitter settings can be done from the remote control:

- Transmitter name setting
- Frequency band/group/channel selection
- RF transmission power setting
- MIC/LINE setting and attenuator setting for audio input level
- Low-cut filter setting
- Power save setting
- Resetting accumulated use time
- Audio codec mode setting
- Internal signal setting
- POWER switch lock setting

For details on menu operation, see “Setting Menus” (page 10).

To perform remote control, the receiver must be equipped with a control function for the setting you want to control. For details, refer to the operating instructions supplied with the receiver.

To cancel the Cross Remote

In the RF REMOTE indication, select OFF.

Notes on the Cross Remote

The wireless remote control function on the transmitter uses the 2.4-GHz band and may thus be subject to interference from other devices.

- When pairing fails (“Pairing fail” is displayed), successful communication between the transmitter and the receiver has not occurred within a given amount of time. Pairing may be harder to do when another receiver is engaged in pairing nearby.
- When it becomes hard to use the remote control, the remote control may be improved by switching the wireless remote control function off, then on again in the RF REMOTE display, then re-pairing with the transmitter (change to a channel with less interference).

Using the Encrypted Transmission Function

The unit is capable of transmitting encrypted signals to prevent unwanted surveillance.

To use the function, select one of the following encryption modes.

Encryption key modes (SECURE KEY / AES256):

An encryption key is automatically generated by the transmitter and used by both the transmitter and receiver in these one-to-one encrypted transmission modes.

The SECURE KEY mode is compatible with first and second generation DWX-series devices.

The AES256 mode uses AES 256-bit encryption for a higher level of security in transmissions.

Password mode (PASSWORD): A user-created password of up to 8 characters can be set for multiple transmitters (this unit) and receivers in this mode. This allows encrypted transmission within a group.

Note

Make sure that encryption mode settings are identical on both the transmitter (this unit) and the receiver.

Using the encryption key modes (SECURE KEY / AES256)

Use these modes for one-to-one encrypted transmission between one transmitter (this unit) and one receiver. To enable encrypted transmission in these modes, an encryption key that cannot be read from the outside is automatically generated by the unit, and the key is transmitted to the receiver via the wireless remote control function.

A new encryption key for the transmitter (this unit) and receiver is automatically generated for each key transmission, resulting in highly secure communication. The encryption key for the transmitter (this unit) and receiver is retained when the unit is turned off, allowing you to resume the same encrypted transmission the next time you turn the unit on.

- 1 Prepare the transmitter (this unit).
 - ① Hold down the SET button in the unit’s ENCRYPTION screen until the setting value blinks.
 - ② Use the + and – buttons to select SECURE KEY or AES256, and press the SET button.
- 2 Prepare the receiver.

Set the receiver that will receive the encryption key to SECURE KEY or AES256.

For details on receiver operations, refer to the receiver’s operating instructions.

3 Exchange the encryption key.

On the receiver side, select REMOTE (wireless remote) as the encryption key exchange method, and perform encryption key exchange.

REMOTE cannot be selected when the wireless remote control function is disabled.

Note

If the receiver does not support AES256 mode, select SECURE KEY.

For details, refer to the receiver's operating instructions.

The unit searches for the receiver with which it is paired.

When the receiver is found, the encryption key is exchanged, and encrypted transmission begins.

Using the password mode (PASSWORD)

Use this mode for encrypted transmissions between multiple paired transmitters (this unit) and receivers. When the same user-created password is set on both the transmitters (this unit) and the receivers, the audio signal can be decoded. This mode is useful when you want to operate multiple transmitters (this unit) and receivers as a group, or receive transmissions from a single transmitter (this unit) on multiple receivers at the same time.

1 Hold down the SET button in the unit's ENCRYPTION screen until the setting value blinks.

2 Use the + and – buttons to select PASSWORD, and press the SET button.

3 Enter a password of up to 8 characters on the unit.

For details on how to enter the password, see the procedure described in "Unit name setting (NAME)" (page 10).

4 Set the encrypted transmission setting on the receiver to PASSWORD.

5 Set the same password that you set for the unit on the receiver.

For details on receiver operations, refer to the receiver's operating instructions.

Note

We recommend changing the password periodically.

Basic Menu Operations

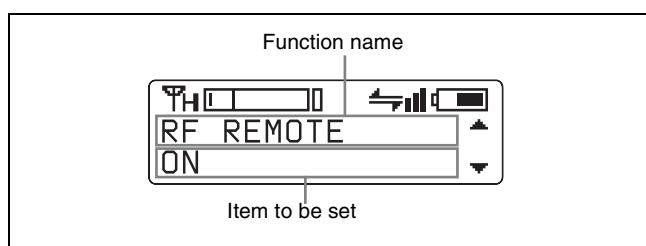

1 Press the + or – button repeatedly until the function to be set appears.

Holding down the + and – buttons allows you to cycle through screens quickly.

In addition, holding down the + button while the first setting item of the menu is displayed allows you to jump to the last setting item, while holding down the – button while the last setting item of the menu is displayed allows you to jump to the first setting item.

2 Hold down the SET button until the item to be set flashes.

3 Press the + or – button to change the setting.

4 Press the SET button to enter the setting.

Setting items in the menu

- NAME (transmitter name) setting
- BAND (frequency band) selection
- GP/CH (group/channel) selection
- AF ATT (audio attenuator level) setting
- LCF (low-cut filter) setting
- LOCK function
- POWER SAVE setting
- BATTERY TYPE (battery type) setting
- RF REMOTE (wireless remote control) function
- SEARCH RX (receiver search) function
- CODEC MODE (audio codec mode) setting
- ENCRYPTION (encrypted transmission function) setting
- INPUT LEVEL (audio input level) setting
- AF PHASE (audio phase switch) setting
- INTERNAL SG (internal signal generator) function
- RF POWER (RF transmission power) setting
- MAX RF POWER (maximum RF transmission power) setting
- TIME (accumulated use time) indication
- BRIGHTNESS (display brightness) setting
- DIMMER MODE (automatic display dimmer) setting
- USER MEMORY (settings storage) function
- POWER PRIORITY (power source priority) setting
- FACTORY PRESET (factory settings) function
- VERSION (software version) display

Setting Menu

The functions and parameters of the settings menu are explained here. Underlined items are the factory setting.

Unit name setting (NAME)

You can specify a transmitter name of up to 16 characters. The factory setting for the transmitter name is the model name and serial number. The transmitter name is sent to the receiver as metadata and is used by the receiver to distinguish between different transmitters.

- +**: The first press on the + button displays the character set. You can then use the + and – buttons to select the desired character. And then, pressing the SET button adds the selected character to the end of the current name.
- : Deletes the last character in the current name.
- SET**: Enters the character or edited name.

Note

You cannot insert or delete a character in the middle of the name.

Using wireless remote control, this function can be controlled from the receiver and other devices.

For details on wireless remote control function, see “Using Cross Remote” (page 7).

Selecting the frequency band (BAND)

Match the frequency range on this transmitter to that of the Sony digital wireless receiver.

See “Carrier Frequencies and Channel Steps” (page 20) for differences in frequency ranges that can be set for optional receivers combined with this transmitter.

For details on groups and channels included in each frequency band, refer to the frequency lists.

Using wireless remote control, this function can be controlled from the receiver and other devices.

For details on wireless remote control function, see “Using Cross Remote” (page 7).

Notes

- The setting for this function cannot be changed during actual signal transmission. To change the setting, turn off the transmitter first. Then, while holding down the SET button, turn the power on. Then change the setting after the signal transmission has stopped.
- Be sure to select the group/channel right after selecting the frequency band. To start signal transmission with the selected frequency band/group/channel, turn off the power and then turn it on again.

Selecting the group/channel (GP/CH)

See “Carrier Frequencies and Channel Steps” (page 20) for factory settings.

For details, see “Selecting the group/channel” (page 6).

Using wireless remote control, this function can be controlled from the receiver and other devices.

For details on wireless remote control function, see “Using Cross Remote” (page 7).

Audio attenuator setting (AF ATT)

When INPUT LEVEL is set to MIC, select the attenuator level for audio inputs.

Note

This setting cannot be changed when INPUT LEVEL is set to LINE.

Input audio from the connected microphone, and use the + and – buttons to select the attenuator level while viewing the input level meter.

The reference levels for the various settings are as follows.

Input	Attenuation (dB)	Reference input level (dBu)	Maximum input level (dBu)	Headroom (dB)
MIC	0	–58	–22	36
	3	–55	–19	
	6	–52	–16	
	9	–49	–13	
	3 dB steps	3 dB steps	3 dB steps	
	45	–13	+23	
	48	–10	+24	34
LINE	–	+4	+24	20

The audio attenuator setting can be changed from the receiver and other devices via the wireless remote control function.

For details, see “Using Cross Remote” (page 7).

Low-cut filter setting (LCF)

The frequency of the low-cut filter can be set.

OFF: Turns off the low-cut filter.

20 30 40 50 60 70 80 90 100

120 140 160 180 200 220 (Hz): Low-cut filter is set according to the selected frequency.

Using wireless remote control, this function can be controlled from the receiver and other devices.

For details on wireless remote control function, see “Using Cross Remote” (page 7).

Lock function (LOCK)

Lock and prevent operations such as those for the POWER button and for settings changes. This prevents you from accidentally turning the unit off, for example.

UNLOCK: Disables operation locks for the POWER button and settings changes.

POWER: Locks POWER button operations only.

SETTING: Locks setting change operations only.

POWER+SETTING: Locks both POWER button and settings change operations.

Disabling the lock function

Set LOCK to UNLOCK.

Changes to the LOCK function are enabled, even when settings change operations are locked.

Lock function shortcuts

You can use to the unit's buttons to enable or disable the POWER+SETTING setting and all lock functions without displaying the settings menu.

To enable the POWER+SETTING setting, hold down the SET and + buttons at the same time until the POWER+SETTING icon appears.

To disable the lock, hold down the SET and – buttons at the same time until the lock indicator disappears.

The lock setting can be changed from the receiver and other devices via the wireless remote control function.

For details, see “Using Cross Remote” (page 7).

Note

Changes to settings via the wireless remote control function are enabled, even when settings change operations are locked. However, changes to settings will not be possible via the wireless remote control function on receivers that do not support the settings change lock function.

For details, refer to the receiver's operating instructions.

Power save setting (POWER SAVE)

To conserve power, this setting allows you to put all transmitter functions to sleep.

ACTIVE: The transmitter operates normally.

SLEEP: The sleep function is on. During sleep, the POWER indicator flashes at 2-second intervals.

To change back to normal operation

During sleep, press the SET, +, or – button.

You can also use the wireless remote control to change the receiver back to normal operation.

For details on wireless remote control function, see “Using Cross Remote” (page 7).

Setting the battery type (BATTERY TYPE)

Set this item according to the type of batteries you use to obtain accurate battery power status indication.

TYPE1: The power status is indicated based on characteristics of new LR6 (size AA) Sony Alkaline batteries. Select this for LR6 (size AA) alkaline batteries.

TYPE2: Select this for rechargeable nickel-metal-hydrate batteries with capacities of about 2000 mAh.

TYPE3: Select this for lithium batteries.

TYPE4: Select this for rechargeable nickel-metal-hydrate batteries with capacities of about 2500 mAh.

Note

The characteristics of batteries change according to battery type and environmental conditions. It is recommended that you learn the characteristics of batteries you use before using them.

Cross Remote (RF REMOTE)

Enable use of the wireless remote control function between the unit and the receiver that will be used with the unit.

OFF: Disables the wireless remote control function.

ON: Enables use of the wireless remote control function with the paired device.

PAIRING: Executes a new pairing.

For details, see “Pairing with a receiver” (page 7).

Receiver search function (SEARCH RX)

Use this function to quickly locate a receiver communicating on the same frequency as the unit.

When the receiver is found, the receiver will react (e.g., the receiver's display will blink).

Note

If a receiver does not support the receiver search function, it will not react.

For details on receiver actions, refer to the receiver's operating instructions.

Searching for receivers

Hold down the SET button in the SEARCH RX screen, and press the SET button again while the “SEARCH? YES” display is blinking.

You can hold down both the + button and – button for 1 second or more at the same time to start the receiver search function.

Audio codec mode setting (CODEC MODE)

MODE1: Audio codec mode that is compatible with first generation DWX-series devices.

MODE2: Audio codec mode that prioritizes short delay times while maintaining transmission stability and high audio quality.

MODE3: Audio codec mode that uses additional signal processing to suppress noise caused by unexpected pulse interference.

MODE4: Audio codec mode that prioritizes audio quality for faithful reproduction while maintaining transmission stability and low delay time.

Under normal circumstances, we recommend using MODE2 (prioritizing delay times) or MODE4 (prioritizing audio quality).

However, use MODE1 when using the unit in conjunction with first generation DWX-series devices, and use MODE3 in environments where unexpected pulse interference may occur.

The audio delay durations that occur when transmitting and receiving with each mode will vary depending on the receiver's operating environment. For details, refer to the receiver's operating instructions.

The audio codec mode setting can be changed from the receiver and other devices via the wireless remote control function.

For details, see "Using Cross Remote" (page 7).

Encrypted transmission function Setting (ENCRYPTION)

Enable the encrypted transmission function.

SECURE KEY: Enables the encryption key mode that is compatible with first and second generation DWX-series devices.

AES256: Enables the AES256 encryption key mode.

PASSWORD: Enables the password mode.

OFF: Disables the encrypted transmission function.

For details, see "Using the Encrypted Transmission Function" (page 8).

Audio input level setting (INPUT LEVEL)

Set the input level to the analog head amp.

Select LINE or MIC according to the audio source connected to the audio input connector.

The factory setting is MIC.

The MIC/LINE setting for the audio input level can be changed from the receiver and other devices via the wireless remote control function.

For details, see "Using Cross Remote" (page 7).

Audio phase switch function (AF PHASE)

Switch the phase when a microphone that outputs with inverted phase is connected.

NORMAL: Disables phase inversion.

INVERT: Enables internal phase inversion on the unit.

Generating an internal signal (INTERNAL SG)

This transmitter generates a 1-kHz reference level sine wave that can be used to adjust or check the audio level of the receiver or the system that you are using. This internal signal is outside the control of the attenuator.

1 kHz: A 1-kHz internal signal is generated.

OFF: An internal signal is not generated.

Note

If the transmitter is turned off while the reference signal function is on, the function will turn off automatically.

Using wireless remote control, this function can be controlled from the receiver and other devices.

For details on wireless remote control function, see "Using Cross Remote" (page 7).

Setting the RF output power (RF POWER)

You can set the RF output power.

2 mW (LOW): transmitted by 2 mW

10 mW (MID): transmitted by 10 mW

25 mW (HIGH): transmitted by 25 mW

Notes

- The setting for this function cannot be changed during actual signal transmission. To change the setting, turn off the transmitter first. Then, while holding down the SET button, turn the power on. And then, change the setting after the signal transmission has stopped.
- To start signal transmission with the selected RF output power setting, turn off the power and then turn it on again.

Using wireless remote control, this function can be controlled from the receiver and other devices.

For details on wireless remote control function, see "Using Cross Remote" (page 7).

The maximum RF output power can be configured on the unit.

For details, see “Setting the maximum RF output power (MAX RF POWER)” (page 13).

Setting the maximum RF output power (MAX RF POWER)

You can set the maximum RF output power of the unit.

2mW MAX: Sets the maximum to 2 mW.

10mW MAX: Sets the maximum to 10 mW.

25mW MAX: Sets the maximum to 25 mW.

Notes

- The setting for this function cannot be changed during actual signal transmission. To change the setting, turn off the transmitter first. Then, while holding down the SET button, turn the power on. And then, change the setting after the signal transmission has stopped.
- To start signal transmission with the selected RF output power setting, turn off the power and then turn it on again.
- Always perform pairing after changing the maximum RF output power setting for a transmitter. If you fail to do so, configuration of RF output power settings via the wireless remote control function may become impossible.

For details on pairing, see “Using Cross Remote” (page 7).

Displaying the accumulated use time (TIME)

You can display the accumulated battery use time as a rough estimate of total transmitter usage. The factory setting is “00:00”.

To reset the accumulated time indication

- 1** Hold down the SET button until the time indication flashes.
- 2** Press the – button so “00:00 RESET” appears, and then press the SET button.

Using wireless remote control, this function can be controlled from the receiver and other devices.

For details on wireless remote control function, see “Using Cross Remote” (page 7).

Setting the brightness of the display (BRIGHTNESS)

Ten levels of brightness can be selected for the organic light-emitting diode display.

The selectable settings are the following:

(Dark) **1 2 3 4 5 6 7 8 9 10** (Bright)

Automatic dimming of the display (DIMMER MODE)

The organic light-emitting diode display can be set to dim or turn off after a certain amount of time.

AUTO OFF: The display turns off after 30 seconds. The display goes on again when you press the SET, +, or – button.

AUTO DIMMER: The display dims after 30 seconds. The display becomes bright again when you press the SET, +, or – button.

ALWAYS ON: The display stays on at the brightness level set with the BRIGHTNESS function.

Settings storage function (USER MEMORY)

Store setting values on the unit, or load previously saved setting values.

When you execute SAVE, the values for the following settings will be saved.

- NAME (transmitter name) setting
- BAND (frequency band) selection
- GP/CH (group/channel) selection
- AF ATT (audio attenuator level) setting
- LCF (low-cut filter) setting
- LOCK function
- RF REMOTE (wireless remote control) function
- CODEC MODE (audio codec mode) setting
- ENCRYPTION (encrypted transmission function) setting
- INPUT LEVEL (audio input level) setting
- AF PHASE (audio phase switch) setting
- RF POWER (RF transmission power) setting
- MAX RF POWER (maximum RF transmission power) setting
- BRIGHTNESS (display brightness) setting
- DIMMER MODE (automatic display dimmer) setting
- POWER PRIORITY (power source priority) setting

When you execute LOAD, the saved setting values will be loaded.

Notes

- This function cannot be executed during actual signal transmission. Turn the unit off, and then hold down the POWER button while pressing the SET button to turn the unit on in a state where signals are not transmitted before execution.
- To start signal transmission after using this function, turn off the unit and then turn it on again.
- You cannot execute LOAD if you have never executed SAVE.
- If you execute LOAD while performing the following operations after setting values were stored, proper communication with the receiver will not be possible. In such cases, perform pairing or encrypted transmission settings again.

- Pairing the unit or establishing encrypted transmission with a different receiver.
- Pairing the receiver that was paired with the unit with a different transmitter.
- Establishing encrypted transmission between the receiver and a different transmitter.

Power source priority setting (POWER PRIORITY)

This device can be configured to use a priority power source when batteries are installed and when connected to a USB power source at the same time.

When the priority power source has been exhausted, it automatically switches to the other power source.

BATTERY: Operates using the batteries as the priority power source.

EXTERNAL: Operates using USB as the primary power source.

Note

The transmitter may temporarily be turned off and restarted when switching power sources depending on the battery type and status and the USB power source.

Resetting parameters to their factory settings (FACTORY PRESET)

All parameter settings can be returned to their factory settings.

Holding down the SET button until a message appears asking for confirmation. Press the + or – button repeatedly to select YES, and then press the SET button to enter. The transmitter parameters are reset to their factory settings.

Notes

- The setting for this function cannot be changed during actual signal transmission. To change the setting, turn off the power first. Then while holding down the SET button, turn the power on. Then change the setting after the signal transmission has stopped.
- To start signal transmission with the factory parameter settings, turn off the power and then turn it on again.

Displaying the software version (VERSION)

The version of the transmitter software can be displayed.

Attaching With the Soft Case

The transmitter can be attached to the user with the supplied soft case.

Changing the direction of the belt clip

The belt clip attached to the rear of the soft case can be rotated 0, 90, 180, or 270 degrees in relation to the unit. When changing the direction of the belt clip, rotate the clip while pressing the switch at the top of the clip, and make sure that the clip is locked into place at your desired position.

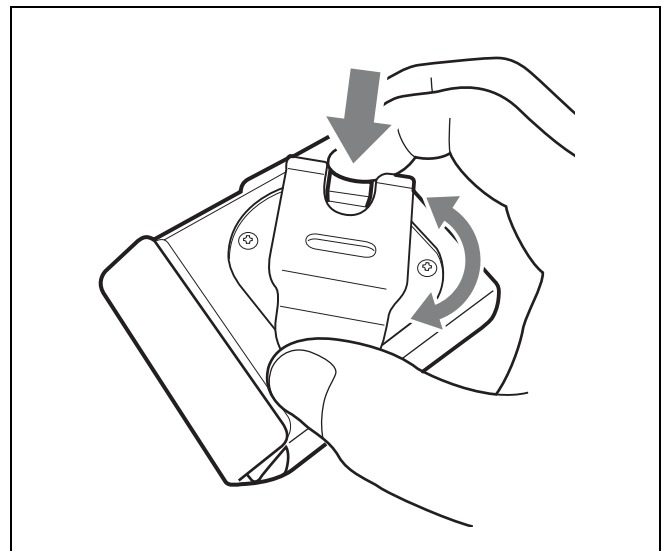

Wrapping the microphone cable around the soft case

A hook and loop fastener is located at the bottom rear of the soft case for securing the lavalier microphone's cable after the unit is inserted into the case.

By wrapping the microphone cable that is connected to the unit around this fastener, you can adjust the length of the cable and reduce the stress that is applied to the unit when the cable is pulled.

Rear

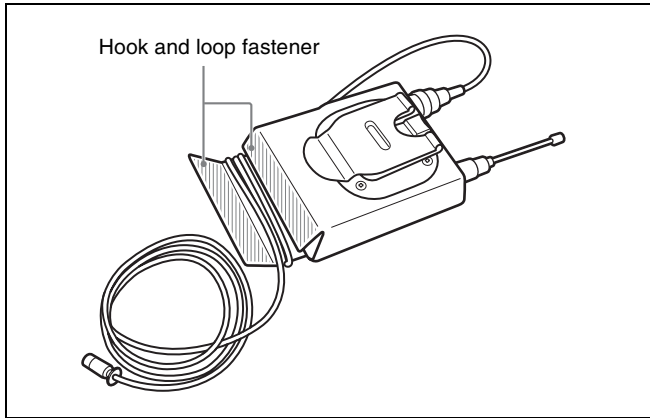

Front

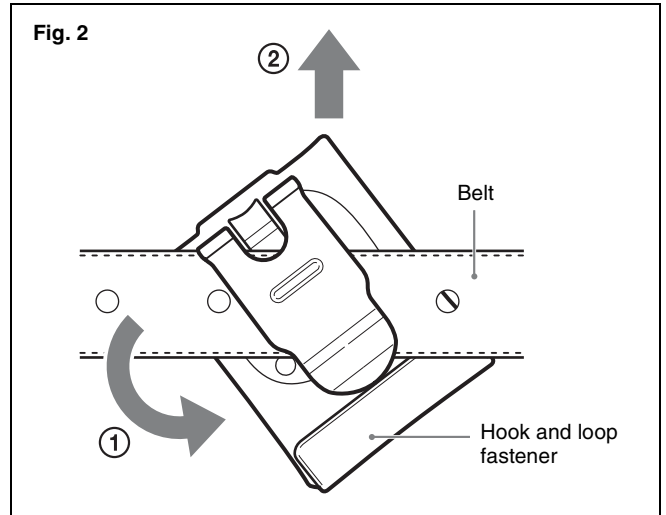
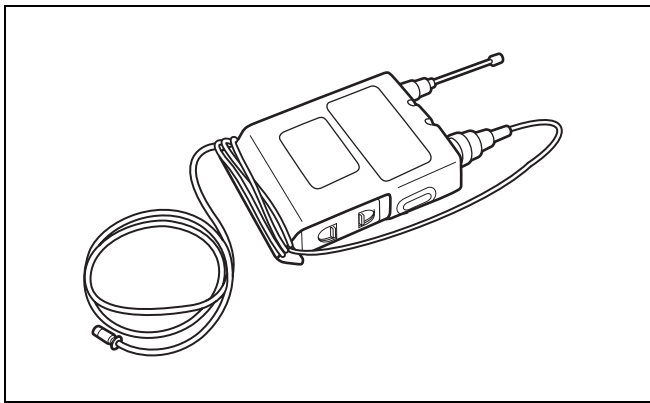

Removing the unit from a belt

When the soft case is attached to a belt with the unit's antenna pointing up, be careful to avoid getting the soft case's hook and loop fastener caught on the belt during removal.

The hook and loop fastener may open if it gets caught on the belt.

To avoid contact between the fastener and belt, tilt the bottom of the soft case outward (Fig. 1) or rotate the case to the left or right (Fig. 2) during removal.

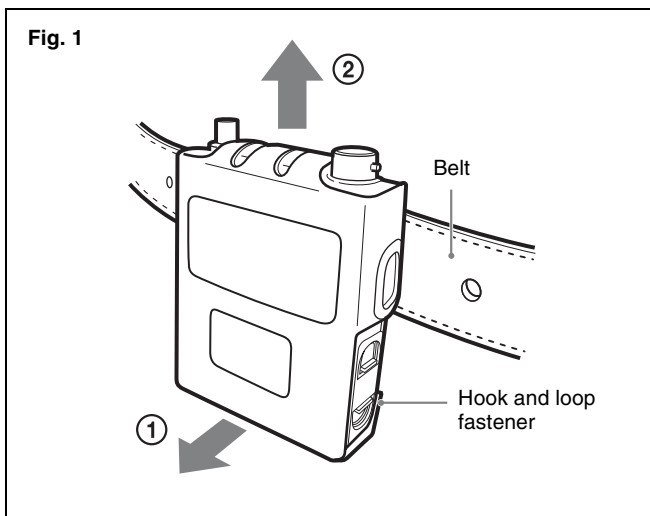

Block Diagram

US model

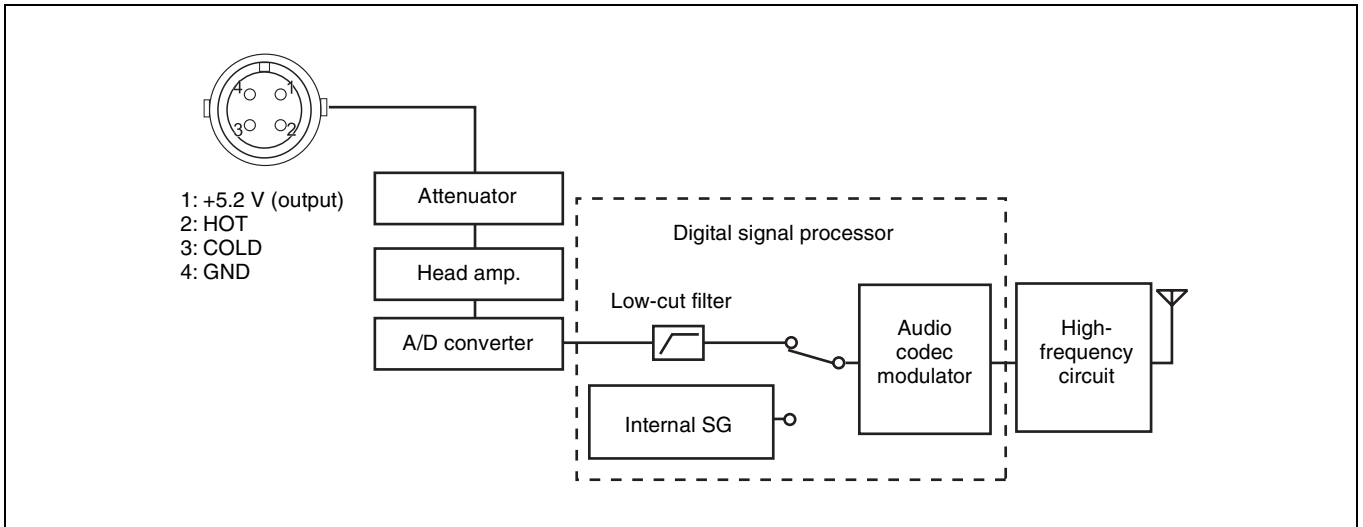

European model

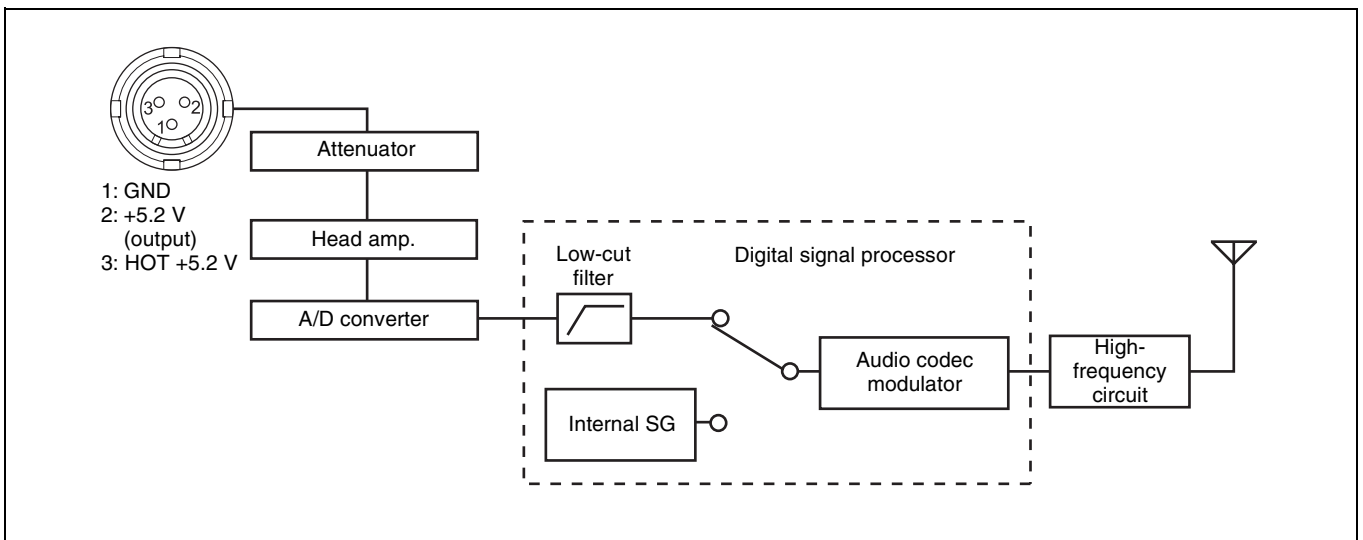

Troubleshooting

If you encounter a problem using this transmitter, use the following checklist to find a solution. For any problems with the receiver or adapter, refer to the operating instructions supplied with the respective device. If the problem persists, consult your Sony dealer.

Symptom	Meanings	Remedy
The transmitter does not turn on.	The batteries are inserted backwards in the battery compartment.	Reinsert the batteries with the correct orientation (<i>see page 5</i>).
	The batteries are exhausted.	Replace the batteries with new ones.
The power is repeatedly turned ON/OFF (screen turns on/off) even when the POWER switch is ON.	The batteries are exhausted.	Replace the batteries with new ones.
The batteries drain quickly.	Manganese batteries are being used.	Use alkaline batteries.
	The transmitter is being used under cold conditions.	The batteries drain quickly under cold conditions.
Interruptions in the reception occurs.	The transmitter is too far from the receiver.	Decrease the distance to the receiver and check the reception.
	The transmission power setting is set to "L".	Increase the transmission power (<i>see page 12</i>).
There is no sound.	The channel setting on the transmitter is different from that on the receiver.	Use the same channel setting on both the transmitter and receiver.
	The setting of the encrypted transmission function on the receiver is different from that on the transmitter.	Confirm that the setting of the encrypted transmission function is the same on both the transmitter and the receiver (<i>see page 8</i>).
	The audio codec mode settings on the receiver and transmitter do not match.	Configure the same audio codec mode setting for both the receiver and transmitter (<i>see page 12</i>).
The sound is weak.	The audio input level of the transmitter is set to LINE or the attenuation level is too high.	If a microphone is connected to the transmitter, set the audio input to MIC (<i>see page 12</i>). While monitoring the audio input level meter, set the attenuator to an appropriate level.
There is distortion in the sound.	The attenuator is set too low for the audio input level of the transmitter.	While monitoring the audio input level meter, set the attenuator to a level that does not produce distortion.
The bass is weak.	The frequency of the low-cut filter is set too high.	While monitoring the sound, decrease the low-cut filter frequency to a level that produces the proper sound quality (<i>see page 10</i>).
There is too much bass.	The microphone connected to the transmitter produces excessive bass because the frequency response of the transmitter extends into the low 20-Hz range.	Use the low-cut filter to cut the bass (<i>see page 10</i>).
The power does not turn off even though the POWER switch is turned to OFF.	The POWER switch is locked.	Turn off the LOCK function (<i>see page 11</i>).
Wireless remote control is not possible.	Pairing has not been established between the transmitter and receiver.	Carry out pairing (<i>see page 7</i>).
	The receiver is too far from the transmitter for communication to occur.	Check the wireless remote control condition level. If it is low, decrease the distance between the transmitter and the receiver (<i>see page 5</i>).
	The transmitter that was paired with the receiver has been paired with another receiver.	On the receiver, carry out pairing again with the transmitter that you want to control.
The display is too dark.	The display brightness is set to low.	Adjust the brightness of the display (<i>see page 13</i>).
The RF output power cannot be configured.	The maximum RF output power function may be set to limit the RF output power.	Check and adjust the setting.

Important Notes on Operation

Notes on using the transmitter

- The use of some frequency bands may be restricted by law, depending on the country or region. Check in advance before use.
- The digital wireless microphone system product must be used within a temperature range of 0 °C to 50 °C (32 °F to 122 °F).
- Operating the transmitter near electrical equipment (motors, transformers, or dimmers) may cause it to be affected by electromagnetic induction. Keep the transmitter as far from such equipment as possible.
- The presence of the lighting equipment may produce electrical interference over the entire frequency range. Position the transmitter so that interference is minimized.
- To avoid degradation of the signal-to-noise ratio, do not use the transmitter in noisy places or in locations subject to vibration, such as the following:
 - near electrical equipment, such as motors, transformers or dimmers
 - near air conditioning equipment or places subject to direct air flow from an air conditioner
 - near public address loudspeakers
 - where adjacent equipment might knock against the tunerKeep the transmitter as far from such equipment as possible or use buffering material.

On cleaning

- If the transmitter is used in a very humid or dusty place or in a place subject to an active gas, clean its surface as well as the connectors with a dry, soft cloth soon after use. Lengthy use of the transmitter in such places or not cleaning it after its use in such places may shorten its life.
- Clean the surface and the connectors of the transmitter with a dry, soft cloth. Never use thinner, benzene, alcohol or any other chemicals, since these may mar the finish.

Notes on simultaneous multi-channel operation

- Keep the microphone at least 30 cm (11 ⁷/₈ inches) away from another transmitter/microphone. When the distances between transmitters need to be closer than the distances above, use a grouping system for multi-channel systems that include both digital wireless and analog wireless devices.

For details, refer to “Frequency Lists”.

- When only digital wireless microphones are being used, keep the transmitter at least 4 meters (13 feet) away from the antenna of a receiver for up to 10 channels, and at least 6 meters (20 feet) away for 11 or more channels.
- When a mixture of digital and analog wireless microphones is being used, keep the transmitter at least 6 meters (20 feet) away from the antenna of a receiver.
- This system should be kept at least 100 meters (328 feet) away from any analog wireless systems using the same frequency when both are being used in a wide area with no walls or obstructions.
- If you experience noise, increase the distance between the transmitter and receiver or decrease the transmission power on the transmitter.

Note on microphone and transmitter combinations

It is recommended that you use the ECM-90BC, ECM-90LM, ECM-77LM, ECM-77BC/9X, ECM-66BC/9X, ECM-44BC/9X, or ECM-FT5BC. Sony lavelier microphone with this transmitter. The transmission signal may cause noise on some microphones. If you experience noise, you may be able to reduce it by changing the position of the microphone cable, moving the microphone connection away from the antenna, or lowering the transmission power.

To prevent electromagnetic interference from portable communication devices

The use of portable telephones and other communication devices near the DWT-B30 may result in malfunction and interference with audio signals. It is recommended that portable communication devices near the DWT-B30 be turned off.

CROSS REMOTE Compatibility

As the unit supports a wider band than previous transmitters, establishing wireless remote communication via CROSS REMOTE between the unit and DWX-series devices requires firmware update for the receiver and RMU-01 unit.

For details on updating the firmware on the DWX-series receiver or RMU-01 unit, contact your Sony representative.

For details on how to check the software version, refer to the device’s operating instructions.

Applicable devices and versions

- DWR-R01D: Version: 1.28 or earlier
- DWR-S01D: Version: 1.16 or earlier
- DWR-R02D: Version: 1.09 or earlier
- DWR-S02D: Version: 1.07 or earlier
- DWR-R02DN: Version 1.18 or earlier
- DWR-S02DN: Version 1.18 or earlier
- RMU-01: Version 1.26 or earlier

Specifications

Transmitting section

Oscillator type	Crystal-controlled PLL synthesizer
RF power output	2 mW/10 mW/25 mW (e.r.p) selectable
Antenna type	$\lambda/4$ flexible wire
Occupied RF bandwidth	192 kHz or less
Audio delay	MODE1: 0.8 ms MODE2: 0.7 ms MODE3: 1.8 ms MODE4: 0.7 ms
Allowable deviation of transmission frequency	± 6.5 ppm
Type of emission	G1E or G1D
Modulation method	$\pi/4$ Shift QPSK

Audio section

Maximum input level	MIC: -22 dBu (with 0 dB attenuator) LINE: +24 dBu
Audio attenuator adjustment range (pad)	0 dB to 48 dB (3 dB steps, MIC input mode only)
Microphone input connector	US model: Sony 4-pin (SMC9-4S) (female) European model: Small 3-pin connector with lock
Input impedance	4.7 kohms or more
Frequency response	20 Hz to 22,000 Hz
T.H.D	MODE1, MODE2, MODE4: 0.03% or less MODE3 : 0.3% or less
Dynamic range	106 dB or more

0 dBu = 0.775 V

General

Operating voltage	3.0 V DC (2 x AA alkaline batteries) 5.0 V DC (USB power source)
Consumption current	Max. 460 mA DC (at 3V DC, 25 mW antenna power)
Battery life	Continuous operating time 6.5 hours (at 25 °C (77 °F), 10-mW output using Sony LR6 (AA)-size alkaline batteries with CODEC MODE set to MODE1 and the wireless remote control function off and DIMMER MODE set to AUTO OFF)

Operating temperature	0 °C to 50 °C (32 °F to 122 °F)
-----------------------	---------------------------------

Note

When used in locations with an ambient temperature of 45 °C (113 °F) or higher, make sure the unit does not come into direct contact with your skin, as it may cause burns due to high temperature.

Storage temperature	-20 °C to +60 °C (-4 °F to +140 °F)
Wireless remote control	2.4-GHz IEEE802.15.4 compliant
Dimensions (unit: mm (inches))	

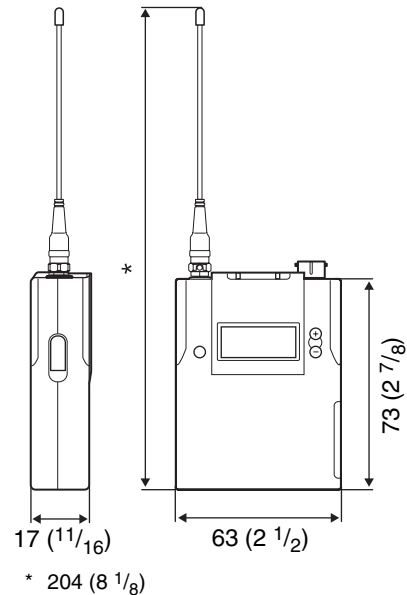

Mass	Approx. 125 g (4.4 oz) Including batteries, not including microphone
Supplied accessories	Spare battery case (1) Soft case (1) Microphone cable (4-pin to XLR-type 3-pin, US model only) (1) Carrying case (1) Scribble sheet (1) Before Using This Unit (4)
Optional accessories	ECM-90BC, ECM-90LM, ECM-77LM, ECM-77BC/9X, ECM-66BC/9X, ECM-44BC/9X, and ECM-FT5BC lavalier microphones

Design and specifications are subject to change without notice.

Carrier Frequencies and Channel Steps

Underlined values represent factory settings.

US model

Channel step: 25 kHz

Model No.	Frequency band	Frequency	Group/channel (factory setting)
UC (TV14-TV36, TV38)	TV14-17	470.125 - 493.875 MHz	<u>00 1801 494.125 MHz</u>
	<u>TV18-21</u>	494.125 - 517.875 MHz	
	TV22-25	518.125 - 541.875 MHz	
	TV26-29	542.125 - 565.875 MHz	
	TV30-33	566.125 - 589.875 MHz	
	TV34-36	590.125 - 607.875 MHz	
	TV37	Not available	
	TV38	614.125 - 615.875 MHz	

The maximum transmission power (MAX RF POWER) for TV38 (614.125 - 615.875 MHz) is 10 mW.

European models

Channel step: 25 kHz

Model No.	Frequency band	Frequency	Group/channel (factory setting)
L (TV21-TV38)	<u>TV21-23</u>	470.025 - 494.000 MHz	<u>00 2101 470.125 MHz</u>
	TV24-26	494.025 - 518.000 MHz	
	TV27-29	518.025 - 542.000 MHz	
	TV30-32	542.025 - 566.000 MHz	
	TV33-35	566.025 - 590.000 MHz	
	TV36-37	590.025 - 606.000 MHz	
	TV38	606.025 - 614.000 MHz	
H (TV33-TV51)	<u>TV33-35</u>	566.025 - 590.000 MHz	<u>00 3301 566.125 MHz</u>
	TV36-37	590.025 - 606.000 MHz	
	TV38	606.025 - 614.000 MHz	
	TV38-40	606.025 - 630.000 MHz	
	TV41	630.025 - 638.000 MHz	
	TV42-44	638.025 - 662.000 MHz	
	TV45-47	662.025 - 686.000 MHz	
	TV48-50	686.025 - 710.000 MHz	
	TV51	710.025 - 714.000 MHz	

