

GLENSOUND ELECTRONICS LTD

GSGC25 PORTABLE ISDN UNIT HANDBOOK CONTENTS

DATE 25/01/01

WP06-259

ISSUE 1

DESCRIPTION

- | | | |
|----|-------------------------------|-------------------|
| 1. | Front & Rear Views | A2-14321 |
| 2. | Block Diagram | A4-14320 |
| 3. | GSGC25 Operating Instructions | WP74-08 (6 Pages) |

G GLENSOUND ELECTRONICS LTD.
6 BROOKS PLACE, MAIDSTONE, KENT, ME14 1HE, ENGLAND

Tel: +44 (0) 1622 753020
+44 (0) 1622 753662
Fax: +44 (0) 1622 762330



©2001
GLENSOUND
 ELECTRONICS LTD

ISSUE

1

DATE

08/01/01

GSGC25

FRONT & REAR VIEWS

DRAWING NUMBER

A2-14321

DRAWN BY

ORIGINALLY DRAWN USING AUTOTRAX

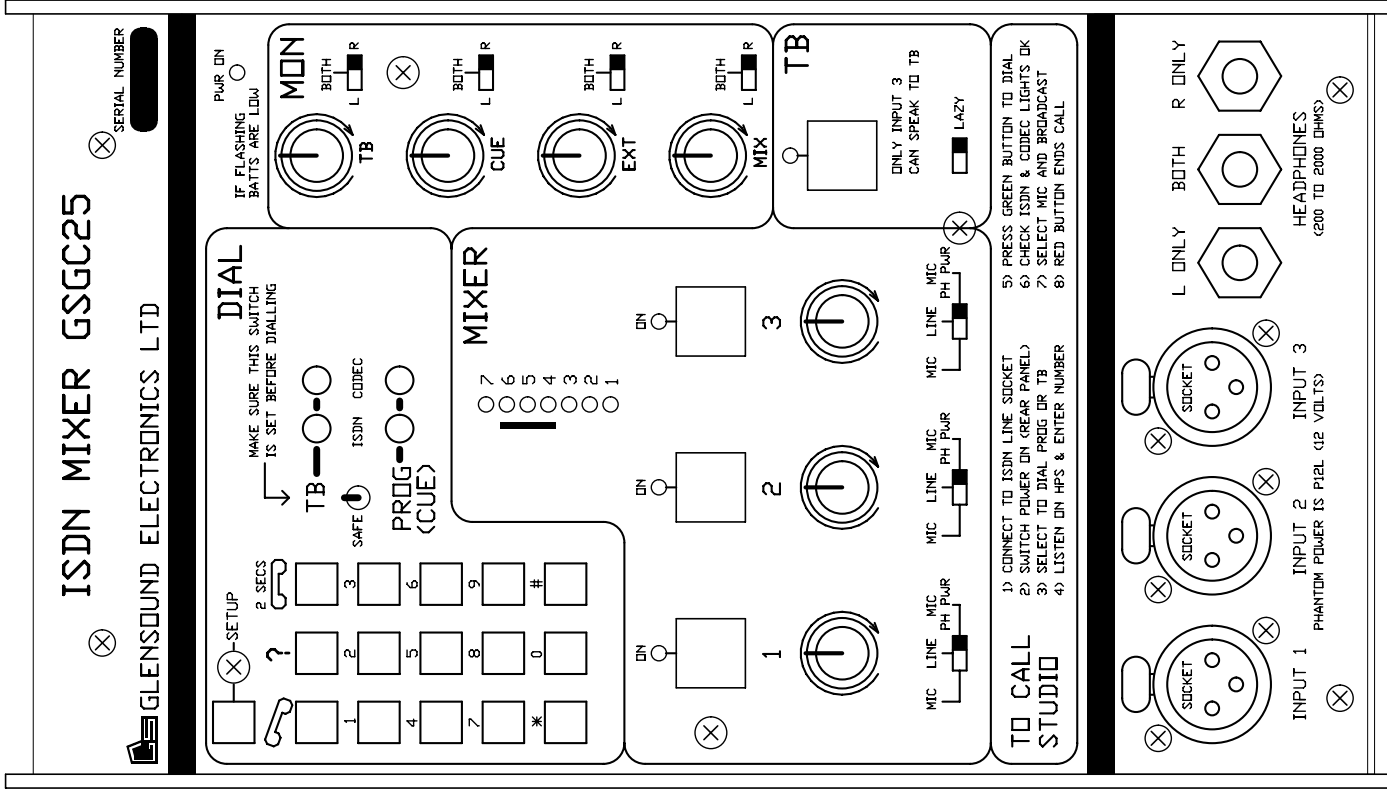
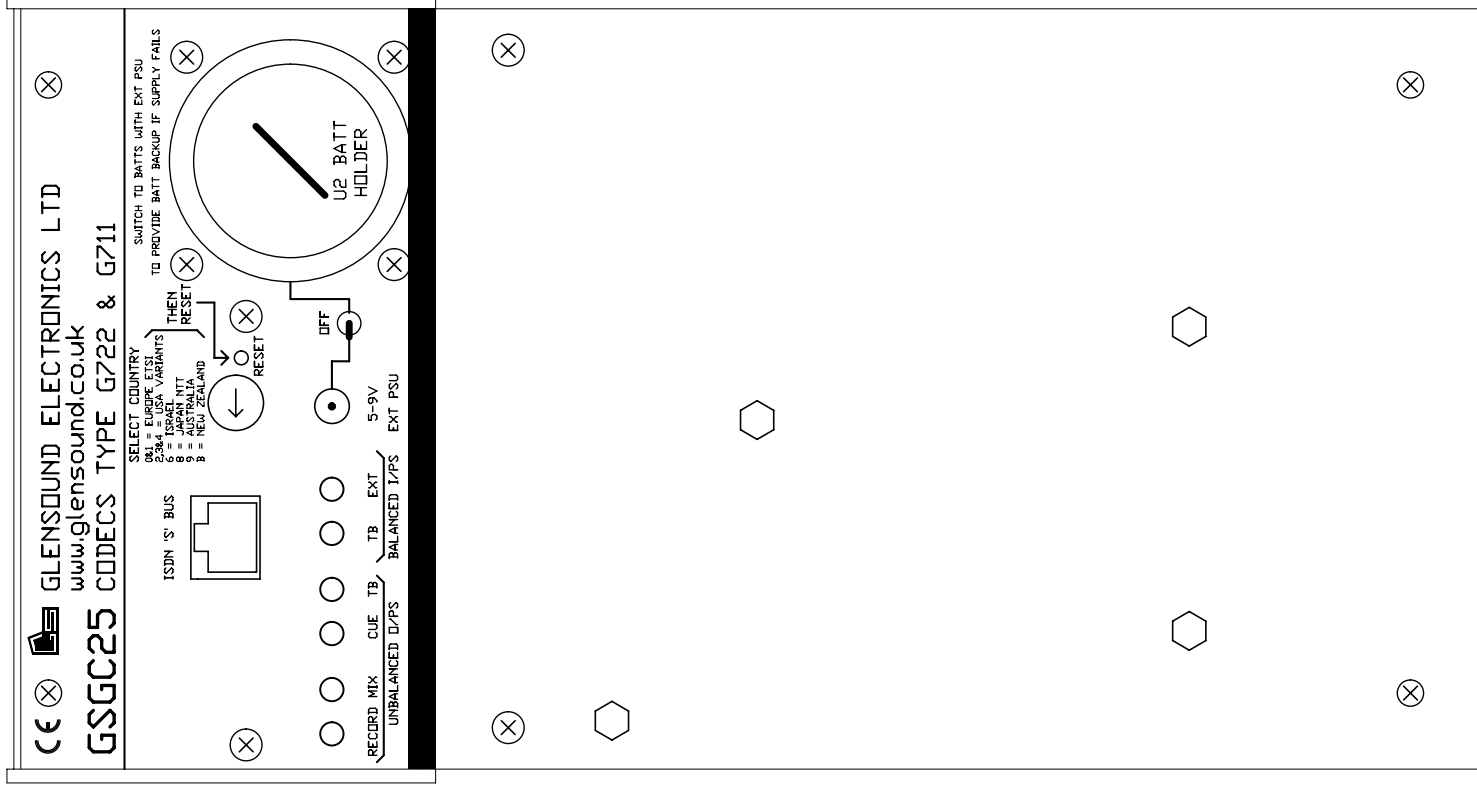

BEND →

BEND →

BEND →

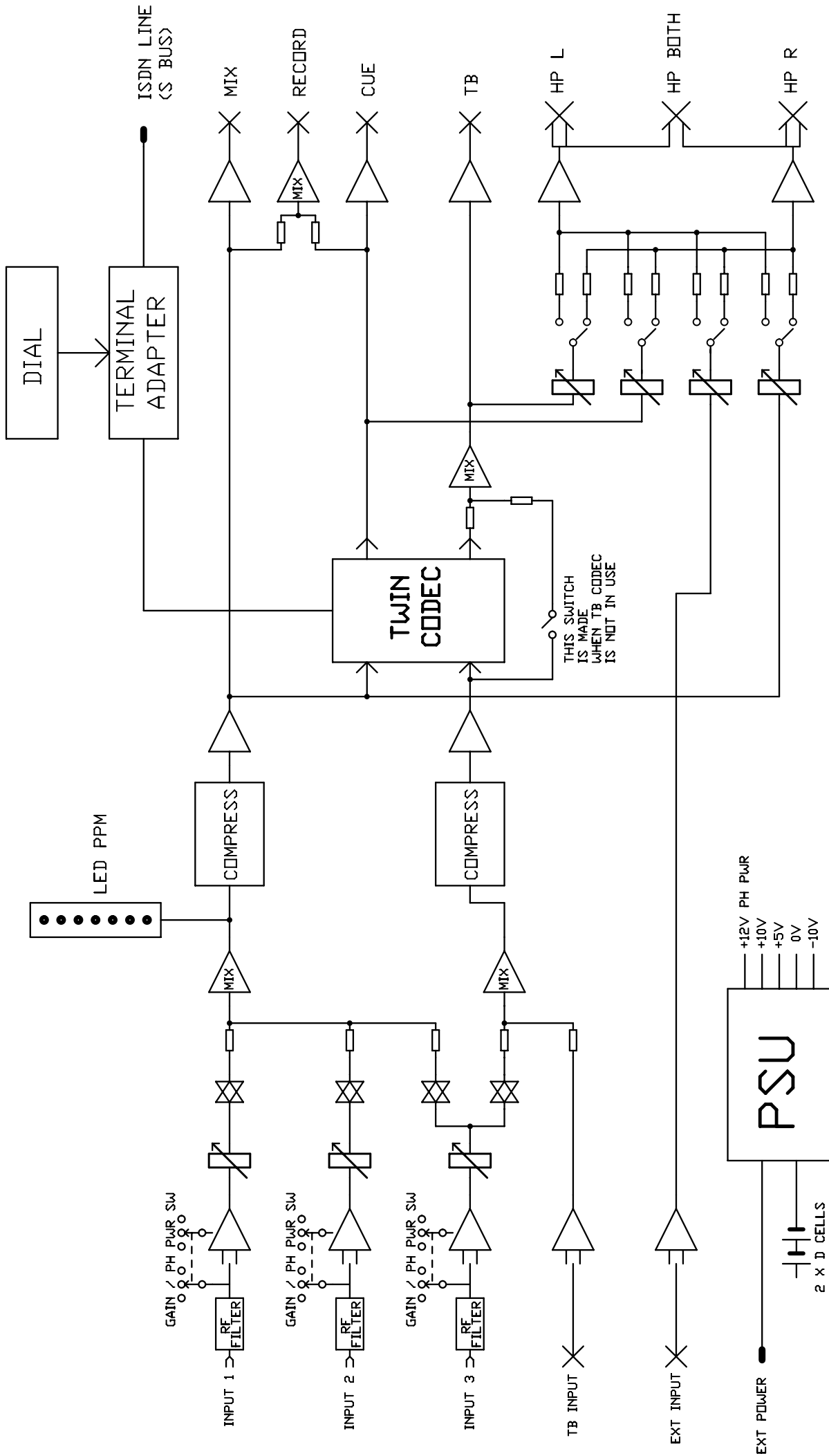

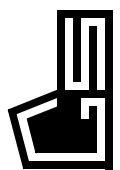
GSGC25 BLOCK DIAGRAM		ISSUE	DRAWING NUMBER	
		1	A4-14320	
		DATE	09/10/00	
		10/10/00		
 © 2000 GLENSOUND ELECTRONICS LTD		ORIGINALLY DRAWN USING AUTITRAX		

GSGC25 OPERATING INSTRUCTIONS

POWER

This equipment can be powered from an external DC supply or from batteries. Battery requirement is for 2 D cells, these must be alkaline such as 'DURACELL DB2'. Tests have shown that at 20⁰C DURACELL DB2 batteries will last for over 5 hours.

There is a 3 position switch on the rear panel (located between the battery compartment & EXT PSU connector), the centre position is off, if the switch is moved in the direction of the battery compartment then power will be from batteries & if the switch is moved in the direction of the EXT PSU connector power will be taken from the external DC supply (providing it is plugged in). If switched to batteries and the external supply is plugged in and present, the equipment will operate from the external supply, if it fails, then the batteries will take over automatically without losing the line.

To turn the box on move the switch either in the direction of the batteries or the EXT PSU. After a few seconds the pwr on LED will light on the front panel, If it flashes the batteries are low and should be replaced.

CONNECTION TO ISDN2 LINE

Supplied with the equipment is a lead with an identical RJ45 plug on both ends. One end must be plugged into the socket on the rear panel marked 'ISDN 'S' BUS' and the other end must be plugged into an ISDN2 circuit.

SELECT COUNTRY:

Next to the 'ISDN 'S' BUS' socket there is a rotary 16 position switch. This selects different versions of terminal adaptor software optimised for different countries. This switch is read by the GSGC25 during power up. If you turn this switch it is therefore essential to reset the GSGC25 either by turning it off and then back on or by pressing the reset button next to the rotary switch.

Switch position		Switch position	
0	EUROPE ETSI standard	6	ISRAEL
1	EUROPE ETSI standard	7	HOLLAND
2	USA AT&T	8	JAPAN NTT
3	USA National ISDN 1	9	AUSTRALIA
4	USA Northern Telecom	A	FRANCE
5	EIRE	B	NEW ZEALAND

Please note that as time passes most countries are moving towards the ETSI standard.

TWO CODECS

Inside the GSGC25 there are two separate Codecs. Each of these two codecs can operate on either G722 or G711 (POTS) algorithms.

Each of the two Codecs need to have an ISDN call established separately.

The two codecs have been assigned different names on the GSGC25, one is called PROG (CUE) & the other TB (short for Talkback). Each of these codecs are connected to different audio functions of the GSGC25.

PROG (CUE) Codec

The PROG (CUE) codec is permanently connected to the output of channels 1 & 2 of the mixer and normally also from the output of the 3rd channel of the mixer (see next paragraph). The return audio from this codec is sent to the headphones via the 'CUE' control in the 'MON' (monitoring) section. The return audio from this codec is also available on a rear panel bantam jack marked 'CUE'.

TB Codec

The TB (Talkback) codec sends the audio from channel 3 of the mixer only when the white TB button is pressed (the lazy switch below this button permanently switches it on). If the TB button or lazy switch are not used then the codec takes audio from a bantam jack connector on the rear panel marked 'TB' (Balanced I/PS). The return audio from this codec is sent to the headphones via the 'TB' control in the 'MON' (monitoring) section. The return audio from this codec is also available on a rear panel bantam jack marked 'TB'.

OTHER FUNCTIONS OF TB KEY: If the TB codec is not in use, then, when the TB key is pressed the output of channel 3 of the mixer is sent to the TB output bantam jack on the rear panel.

ONE KEYPAD – TWO CODECS

To the right of the dialling keypad on the front panel there is a three position 'toggle' switch. This switch controls which of the two codecs the keypad is controlling.

The centre position of this switch is marked 'SAFE' and if switched to this position the keypad has no affect.

The bottom position of this switch is marked 'PROG (CUE)' and if switched in this position the keypad controls the PROG (CUE) codec.

The top position of this switch is marked 'TB' and if switched to this position the keypad controls the TB codec.

TO ANSWER AN INCOMING CALL

This equipment can be set to automatically answer incoming calls or to wait for you to press the green (dial/ answer) button.

If it is configured to be manually answered, an incoming call will cause the red ISDN lights to flash and a ringing will be heard in the headphones. To answer the

call make sure that the toggle switch to the right of the keypad is set to either TB or PROG (depending on which codec you wish to answer the call with) and then momentarily press the green answer button. The red ISDN light should immediately go steady and after a few seconds the green codec light should light. It should now be possible to hear & talk to the studio.

DIALING

To dial the studio first select to dial either the PROG or TB codec. While listening on the headphones dial the number, with each key press a confirmation will be heard, when you have entered the complete number that you wish to dial press (for at least 1 second) the green button. You will then hear in your headphones confirmation of the number being dialled, the type of call being tried (ie broadcast (G722) or telephone (G711)), then 'connected' confirmation of the studio answering and finally 'framed' confirmation of a codec lock being established. The red ISDN light will light when the call has been answered and the line is open and the green codec light will light when a codec lock (frame) has been established. If an incorrect number has been dialled then an error message will be heard.

ENDING A CALL

First select the codec either PROG (CUE) or TB that you wish to disconnect, then press the red hang-up button for at least 2 seconds. 'Cleared' will be heard in the headset and the red ISDN light & green codec light will go out.

MEMORY REDIAL

For each of the 2 codecs up to 99 pre-stored numbers can be stored in non volatile memory (for information on how, see the software setup pages of this information book). To dial one of these stored numbers first select the codec to dial (PROG or TB) then press the '#' key followed by the 2 digit number of the stored location for the number that you wish to dial and then press the green dial button.

HEADPHONE CONNECTION

There is one headphone amplifier that has four sources and it is connected to three jack sockets (A or B gauge). The four sources are TB (The return of the Talkback codec), CUE (The return of the PROG (CUE) codec), EXT (short for external) this comes from a local input that is on a rear panel bantam jack and finally MIX which is the output of the 3 channel mixer (less channel 3 if TB is pressed). Each of these sources has a level control and a switch marked L – BOTH – R , these switches switch their source to either the left only, the right only or both channels of the headphone amplifier. The three headphone jack sockets on the front of the GSGC25 are marked 'L ONLY', 'BOTH' & 'R ONLY', they are wired to the Left only, Both or Right only channels of the headphone amplifier. It is therefore entirely feasible to have different operators listening to different sources from the one GSGC25.

The headphone amplifier is designed for driving medium to high impedance headphones (200 to 2000 Ohms).

REAR PANEL CONNECTORS

There are 6 rear panel 'bantam' jacks, 4 outputs & 2 inputs.

All the outputs are 'unbalanced' and they are:

RECORD: This is a mix of the output of the mixer & the return audio from the PROG (CUE) Codec.

MIX: This is the output of the mixer.

CUE: This is the return audio from the PROG (CUE) Codec.

TB: This is either the return audio from the TB Codec (if connected), or if the TB Codec is not connected then it is the output of channel 3 of the mixer when the TB button is operated.

The inputs are 'balanced' circuits and they are:

TB: This is sent to the TB codec and if the codec is in use it is sent down the line. If the TB codec is not operated then this input is sent to the TB headphone feed & then to the TB output. This input is mixed with the output of channel 3 of the mixer when the TB switch is operated.

EXT: This is sent to the EXT headphone feed.

EXT PSU Socket: This is a 2.5mm DC socket that Mates with RS 486-634, 6 to 9 volts DC are required (Sleeve is -ve).

SOFTWARE SETUP

Many parameters of the GSGC25 can be set up by the operator. It is important to remember that the GSGC25 contains two independent Codecs and each must be set up & programmed individually.

TO ENTER SETUP MODE

Press the set up button for several seconds. (This is the grey button (Top Left))

SETUP TREE

On entering setup a menu of commands is available. A recording informs you of the function of each button which are as follows:-

MAIN MENU

Press	CLEAR	to Leave Setup
	ZERO	for Current settings
	ONE	to change User settings
	TWO	to change ISDN settings
	THREE	to change Memories
	QUERY (?)	to Repeat

0) **CURRENT SETTINGS** A full list of the current settings

1) **USER SETTINGS**

Press CLEAR for Main Menu

Zero for Current User Settings

One to Change Answer Mode. Each Press toggles between:-
1) Auto Answer
1) Manual Answer

Two to Change Progress Reporting. Each Press toggles between:-
2) Full Call Progress
2) Query call Progress

Three to Change Ident.
Enter two digit Ident Number or press # to cancel.

Four to Change Announcement Volume

Five to change Dial Guard Time. Each Press toggles between:-
5) Dial Guard Time is Long
5) Dial Guard Time is Short

Press Query (?) to Repeat or CLEAR to return to Main Menu

2) ISDN SETTINGS

Press **CLEAR** for Main Menu

Zero For Current ISDN Settings

One To Change Incoming Call Types

- 1) Incoming Calls Barred
- 1) Incoming Telephone Calls Only
- 1) Incoming Broadcast Calls Only
- 1) Incoming Broadcast and Telephone Calls

Two To Change Outgoing Call Types

- 2) Outgoing Calls Barred
- 2) Outgoing Telephone Calls Only
- 2) Outgoing Broadcast Calls Only
- 2) Outgoing Broadcast and Telephones Calls

Three To Change Broadcast MSN

Enter Broadcast MSN if any, terminated with * or Press # to Cancel.

Four To Change Telephone MSN

Enter Telephone MSN if any, terminated with * or Press # to Cancel.

Five To Change B Channel Map

- 5) Calls on B2 Only
- 5) Calls on B1 or B2
- 5) Calls on B1 Only

Six To Change SPID

- 6) Enter SPID Terminated with * or Press # to Cancel

Press Query (?) to repeat

Press **CLEAR** to return to Main Menu

3) MEMORIES

It is possible to store up to 99 frequently used numbers in each port of the GSGC9. These numbers are non volatile and are remembered even when the GSGC9 is switched off.

Each number must be 17 digits or less.

Enter the two digit number number of the required store. If you press '#' the operation will be cancelled and you will return to the Main Menu.

Enter New Number (up to 17 digits) terminated with '*' or press '#' to Cancel.