



Glensound
Keeps Working

AOIP2M

**2 Channel Dante Microphone
Preamplifier**

PRODUCT DETAILS



GlenSound Electronics Ltd

Thank you for choosing a new GlenSound product.

All rights reserved.

Information contained in this manual is subject to change without notice, if in doubt please contact us for the latest product information.

If you need any help with your product then we can be contacted at:

GlenSound Electronics Ltd
The Design Buildings
1 – 6 Brooks Place
Maidstone
Kent
ME14 1HE
United Kingdom

Telephone: +44 (0) 1622 753662

EMAIL ADDRESSES

General and Technical enquires: techinfo@glenSound.com

Sales enquires: sales@glenSound.com

IMPORTANT SAFETY INSTRUCTIONS

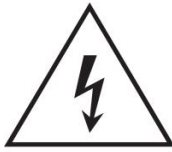

This symbol is intended to warn that dangerous voltages within the product are present and constitute a risk of electric shock.



This symbol is intended to highlight that there are important operating & maintenance instructions in the literature accompanying this unit.

- 1) Read these instructions
- 2) Keep these instructions
- 3) Heed all warnings
- 4) Follow all instructions
- 5) Do not use this apparatus near water
- 6) Clean only with a dry cloth
- 7) Do not block any ventilation openings. Install in accordance with manufacturer's instructions
- 8) Do not install near any heat sources such as radiators, heat registers, stoves, or other apparatus (including amplifiers) that produce heat
- 9) Do not defeat the safety purpose of the polarized or grounding type plug. A polarized plug has 2 blades with one wider than the other. A grounding type plug has 2 blades and third grounding prong. The wider blade or the 3rd prong are provided for your safety. If the provided plug does not fit into your outlet, consult an electrician for replacement of the obsolete outlet
- 10) Protect the power cord from being walked on or pinched, particularly at plugs, convenience receptacles and the point where they exit from the apparatus
- 11) Only use attachments/ accessories specified/ supplied by the manufacturer
- 12) Use only with the cart, stand, tripod, bracket, or table specified by the manufacturer, or sold with the apparatus. When a cart is used, use caution when moving the cart/ apparatus combination to avoid injury from tip over
- 13) Unplug this apparatus during lightning storms or when unused for long periods of time
- 14) Refer all servicing to qualified service personnel. Servicing is required when the apparatus has been damaged in any way, such as power supply cord or plug is damaged, liquid has been spilled or objects have fallen into the apparatus, the apparatus has been exposed to rain or moisture, does not operate normally, or has been dropped
- 15) Do not attempt to modify this product. Doing so could result in personal injury and/ or product failure

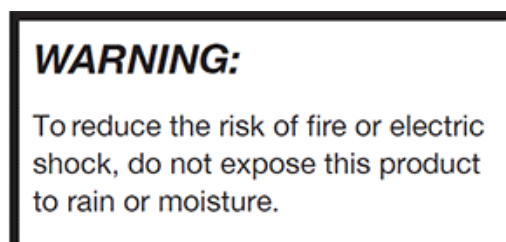
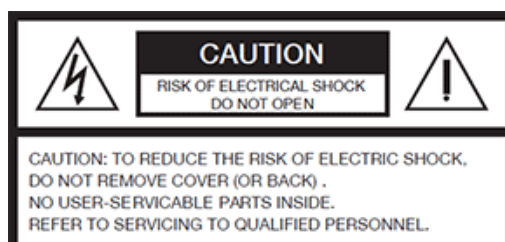

PRODUCT WARRANTY

All equipment is fully tested before dispatch and carefully designed to provide you with trouble free use for many years.

We have a policy of supporting products for as long as possible and guarantee to be able to support your product for a minimum of 10 years.

For a period of one year after the goods have been despatched the Company will guarantee the goods against any defect developing after proper use providing such defects arise solely from faulty materials or workmanship and that the Customer shall return the goods to the Company's works or their local dealer.

All non-wear parts are guaranteed for 2 years after despatch and any defect developing after proper use from faulty materials or workmanship will be repaired under this warranty providing the Customer returns the goods to the Company's works or their local dealer.



EU DECLARATION OF CONFORMITY

AOIP2M

2 Channel Dante Microphone Preamplifier

This declaration of conformity is issued under the sole responsibility of the manufacturer.

This equipment is manufactured by Glensound Electronics Ltd of Brooks Place Maidstone Kent ME14 1HE is  marked and conforms to the following Union harmonisation legislation:

Emissions:	BS EN55032:2015
Immunity:	BS EN55035:2017

Signed for and on behalf of Glensound Electronics Ltd.



Marc Wilson, Managing Director
Maidstone, Kent, England

Date: 02/09/2022

RoHS DIRECTIVE

RoHS 2 Directive 2011/65/EU restricts the use of the hazardous substances listed below in electrical and electronic equipment.

This product conforms to the above directive and for these purposes, the maximum concentration values of the restricted substances by weight in homogenous materials are:

Lead	0.1%
Mercury	0.1%
Hexavalent Chromium	0.1%
Polybrominated Biphenyls	0.1%
Polybrominated Diphenyl Ethers	0.1%
Cadmium	0.01%

WASTE ELECTRICAL AND ELECTRONIC EQUIPMENT REGULATIONS 2006 (WEEE)

GlenSound Electronics Ltd is registered for business to business sales of WEEE in the UK our registration number is:

WEE/JJ0074UR

GLENSOUND AOIP2M

Handbook Contents

Description Issue 1.0 02/09/22 Page No.

Contents

IMPORTANT SAFETY INSTRUCTIONS	3
PRODUCT WARRANTY	4
CE	5
RoHS DIRECTIVE.....	6
WASTE ELECTRICAL AND ELECTRONIC EQUIPMENT REGULATIONS 2006 (WEEE)....	7
Handbook Contents	8
Overview.....	9
AOIP2M Front Panel Layout	10
Power LED	10
Input Gain control.....	10
Mic activity.....	10
Phantom power switch	10
Phantom power indicator	10
AOIP2M Rear Panel Layout.....	11
Microphone inputs.....	11
DC Power Input jack	11
USB connector.....	11
Network RJ45 etherCON	11
Audio Block Diagram	12
Connecting The AOIP2M To A Dante Network.....	13
Getting Dante Controller	13
Connecting AOIP2M device to the network	13
Audio Over IP Network	13
Running Dante Controller	14
Dante Controller TIP	14
Device not showing up in Dante Controller	15
AES67 Mode	16
Turning On AES67 Mode.....	16
Sending AES67 Audio	16
Receiving AES67 Audio.....	17
AES67 Restrictions	18
Updating The Dante firmware	19
Updating the device	19
Wiring Information.....	21

Overview

The GlenSound AOIP2M is an analogue to digital converter with high quality Microphone Preamplifiers designed to connect microphones to a Dante® audio network.

Dante® network audio is a common protocol for distributing high quality linear audio over standard IP networks and it is widely used by many audio equipment manufacturers. The AOIP2M Dante® audio interface is compatible with all Dante® audio interfaces across all manufacturers. Further details of Dante® network audio can be found at www.audinate.com

Intended for live on-air broadcast applications, the AOIP2M is built into a rugged lightweight aluminium chassis with anaodised and laser etched panels. Holes suitable for temporarily attaching the unit with cable ties to hold it in place are provided for ease of installation.

AES67 is supported by the Audinate's Ultimo chipset and can be easily turned on/off via Dante® controller.

Sample frequencies from 44.1 to 96kHz are supported by the unit when connected to a Dante® network and 48kHz is supported when in AES67 mode.

AOIP2M Front Panel Layout



Power LED

Power LED for power indication.

Input Gain control

Potentiometer for controlling microphone input gain.

Mic activity

Post-pot mic activity LEDs for monitoring Microphone level.

Phantom power switch

Press and hold for a few seconds to toggle +48V phantom power on for the selected Mic channel.

Phantom power indicator

LED to indicate if +48V phantom power is on or off. Illuminates red.

AOIP2M Rear Panel Layout

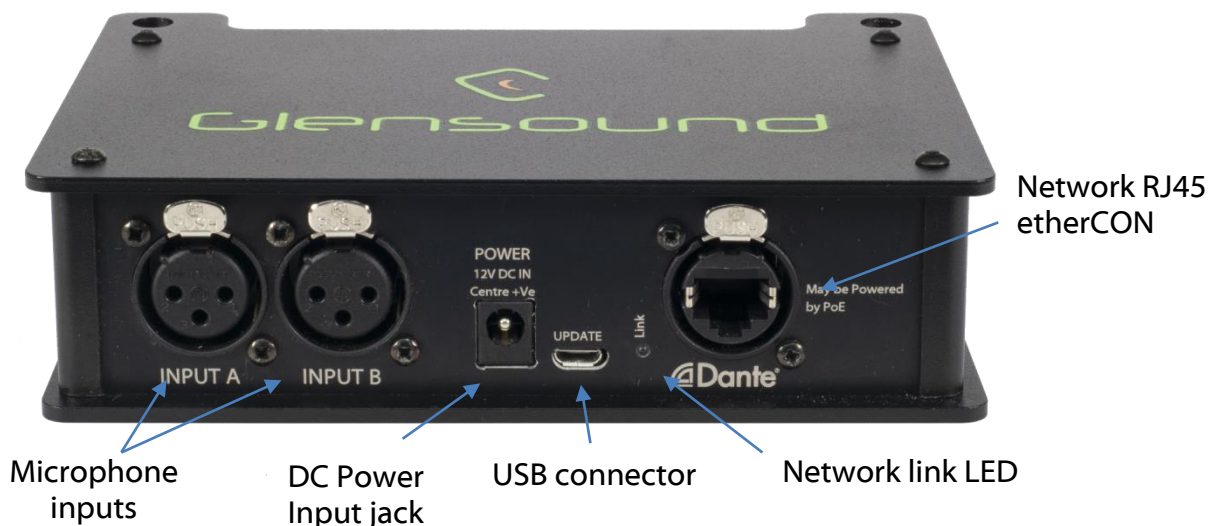

Microphone inputs

Two high quality microphone preamplifiers. See the end of the manual for wiring information.

DC Power Input jack

A standard DC IN barrel jack connector for 12V 1A DC input. The center pin is 2.5mm. It is wired center pin + Volts.

USB connector

Micro USB connector for device firmware updates.

Network RJ45 etherCON

The Primary 100Mbps ethernet IP interface allow connection to a Dante network. The amber LED indicates network activity. The connector is a Neutrik etherCON which allows locking connections with a compatible etherCON cable.

The AOIP2M can be powered via PoE or the DC jack input or both at the same time for redundancy. The PoE source used to power the device can be a mid-span adapter or a network switch with PoE conforming to IEEE 802.3af.

Audio Block Diagram

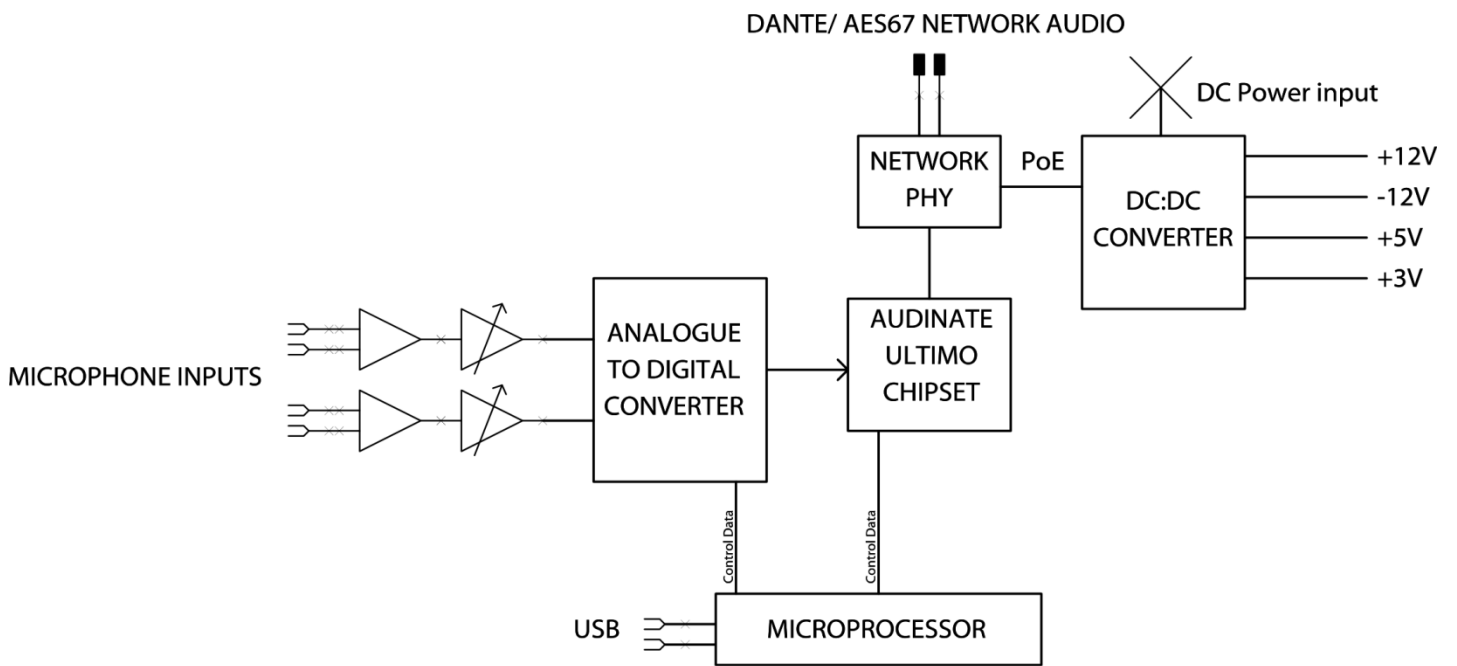

Connecting The AOIP2M To A Dante Network

The AOIP2M is a network audio device utilizing the reliable and versatile Dante audio over IP protocol. Dante is a proprietary system (although very widely used) the originators of which are Audinate.

The information below is only meant as a very basic guide. Full details of the power of Dante network audio and instructions for using it can be found at www.audinate.com

Getting Dante Controller

If you are connecting the AOIP2M to a new Dante network the first thing you will need to do is to get the free Dante controller software from Audinate.

This can be downloaded by visiting Audinate's web site at www.audinate.com

Connecting AOIP2M device to the network

The AOIP2M can be connected to the network that you are going to use for your audio distribution simply by plugging in to the RJ45 network connections on the rear. Once connected to the network it will be possible to see the AOIP2M from within the Dante controller and route its' audio circuits.

Audio Over IP Network

We strongly recommend that you consider your network topology carefully and would not recommend sharing broadcast audio and general data on the same network.

For more details of audio over IP network structure please visit www.audinate.com

Running Dante Controller

At the time of writing this manual the Dante Controller looks as per the screenshot below:

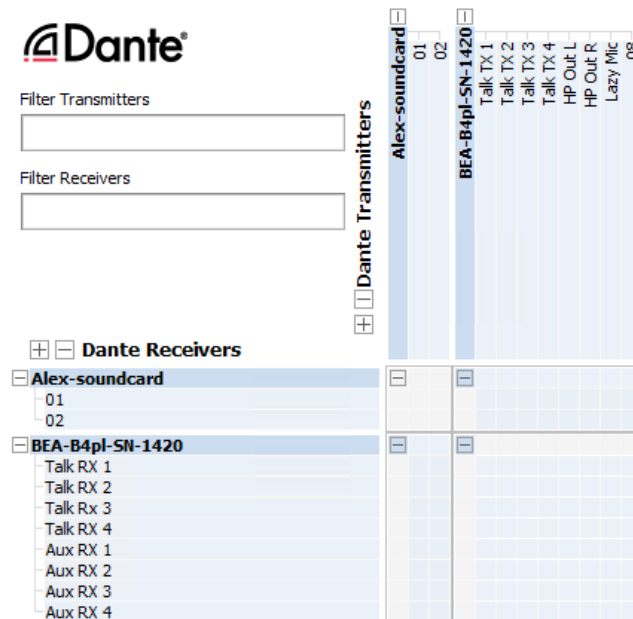

The AOIP2M will have been named at the factory during test to allow them to be identified by the Dante controller.

The format used for the factory name is:

'AOIP2M-SN-XXXX'

Where 'AOIP2M' refers to the Glensound product i.e. AOIP2M

The 'SN-XXXX' refers to the serial number of the AOIP2M which can be found printed on the rear or side of the unit.

The unit may be renamed in Dante controller by opening the 'Device view' window and selecting AOIP2M in the drop-down menu. Go to the 'Device Config' tab and change the name with the Rename Device box.

Note if you upload a new DNT file or clear the devices config then the name will change to 'AOIP2M-xxXxXx' whereby the 'X's refer to the devices MAC address.

Dante Controller TIP

If you have never run Dante controller before then make sure that on the bottom left of the Dante controllers' screen 'P' or 'S' is next to a green square as this indicates that it is connected to a network. By clicking 'P' or 'S' a pop up box opens to allow you to set what network interface the controller is using.

Device not showing up in Dante Controller

If your Dante device does not show up in Dante Controller then the most likely issue is that the device's IP Address is not appropriate for your network.

- A) It maybe that the device is set to obtain an IP address automatically using DHCP (this is the default configuration) and your network is setup for fixed IP addresses only and does not have a DHCP server.
- B) It maybe that the device has had a fixed IP address assigned but that this address is not suitable for your network.

The solution to both scenarios is basically the same.

- 1) You must connect your Dante device directly to the Ethernet port of your computer using an Ethernet cable.
- 2) Make sure that your computer is set to 'Obtain an IP address automatically'
- 3) After a few minutes the Dante device should now appear in Dante Controller.
- 4) Double click the device name to open up device view.
- 5) Open up the 'Network Config' tab
- 6) Either turn on 'Obtain an IP Address Automatically' or correctly configure the 'Manually configure an IP Address' options for your network.
- 7) Click on 'Apply' to confirm the new settings, then disconnect the computer and reconnect the Dante device to your network.

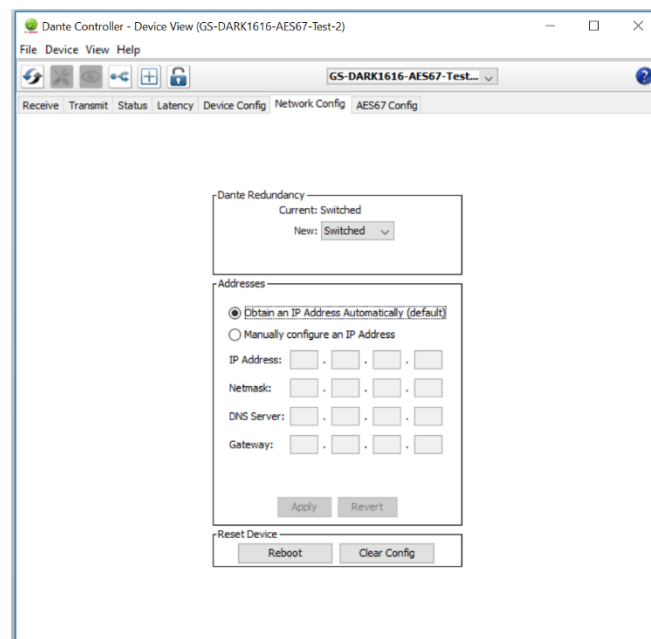

AES67 Mode

The AOIP2M uses a chipset from Audinate called the Ultimo for its network audio interface. Audinate are the company behind Dante and as such the primary network audio protocol is Dante, however Audinate have enabled their chip to comply with AES67 and therefore the AOIP2M can be set to AES67 mode for interaction with other AES67 devices.

Please note however that Glensound are relying on Audinate's AES67 interface and are unfortunately not able to provide full AES67 support for the unit. AES67 support should be sought directly from Audinate.

Turning On AES67 Mode

If you want to use your AOIP2M on an AES67 network and it has not been set to AES67 mode then this can be set in Dante controller by double clicking the AOIP2M to open the Device View window where you will find an AES67 tab to enable AES67 support.

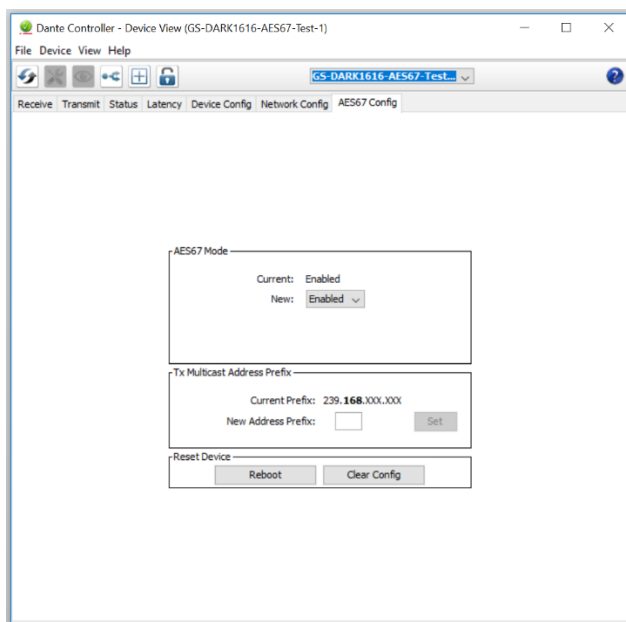

Once the AES67 drop down box has been enabled you'll have to reboot the AOIP2M for the change to take effect. After the reboot go back to the AES67 tab and set the multicast prefix address to one that is suitable for your network.

Sending AES67 Audio

To transmit AES67 audio to the network a multicast flow must first be setup.

This is done by selecting the 'Create New Multicast Flow' Icon  in the Device View.

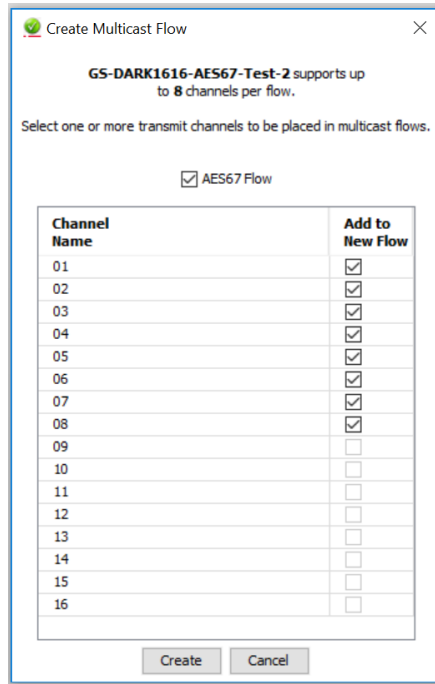

Tick the AES67 Flow check box, then select channels to be included in the flow then click 'Create'

Once set the flows can be seen in the transmit tab of the device view.

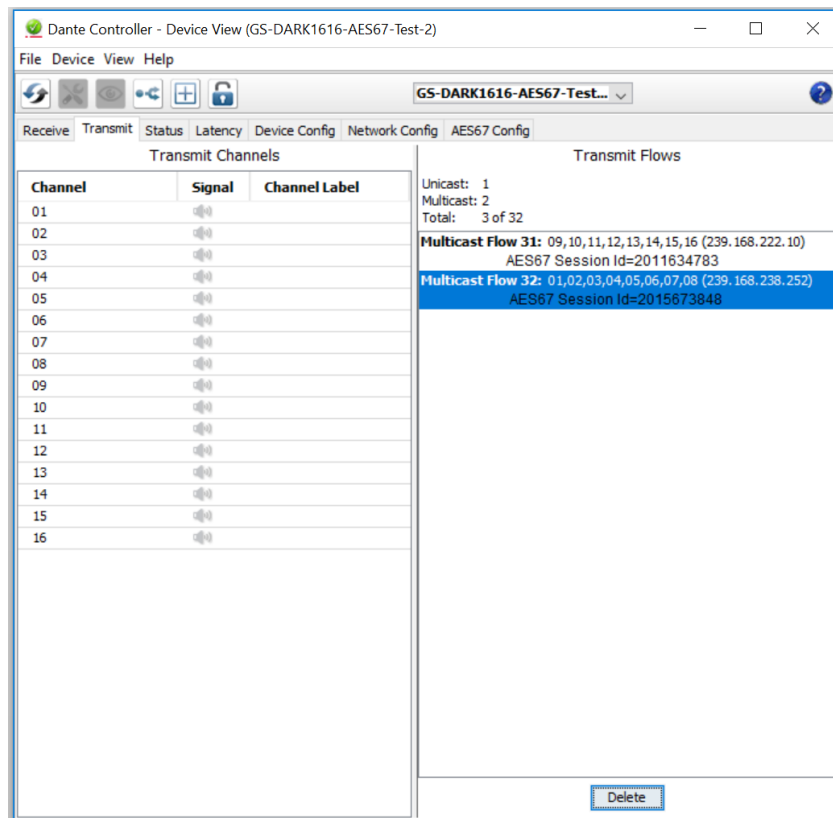

Receiving AES67 Audio

Once a compatible AES67 stream is detected on the network by Dante Controller the AES67 flows will appear in the Dante Transmitters section in the Routing tab.

AES67 Restrictions

AES67 flows can only be generated with the following constraints:

- Multicast Only
- Non-redundant
- Destination address in range 239.nnn.0.0 to 239.nnn.255.255 (239.nnn/16), port 5004
- 48kHz sampling rate
- 24 bit linear (L24) encoding
- 1 msec packet time
- Up to 8 channels per stream

Received AES67 flows have the following constraints:

- Multicast Only
- Non-redundant
- Destination address in range 239.nnn.0.0 to 239.nnn.255.255 (239.nnn/16), port 5004. Must match destination address range.
- 48kHz sampling rate
- L16 or L24 encoding
- 125usec, 250usec, 333usec, 1 msec packet time
- Up to 8 channels per stream

Updating The Dante firmware

The AOIP2M has Dante specific firmware that runs inside the Dante chipset, known as Ultimo.

The Ultimo Chipset is a device supplied by Audinate that does most of the processing for the actual Dante/ AES67 network audio streams. There is one Ultimo Chipset in each AOIP2M.

Updating the device

The firmware that runs in the Ultimo Chipset can be updated using the built-in Dante Updater in Dante Controller. Please ensure you have a connection to the internet.

If you want to update devices on a Dante network that is not connected to the Internet, you can download the files ahead of time to your computer, move the computer to the offline network, and then update the devices using the downloaded files.

Dante Updater displays a list of all online firmware files in the Library tab, so you can choose which files to download, or even download the entire database if you are not sure which files you will need. For further details please visit www.audinate.com

1.

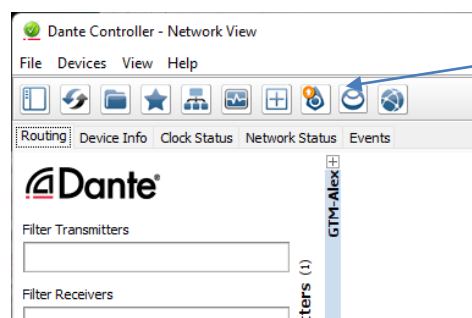

Dante controller notifies you if a device on your network is out of date.

Click the icon

2.

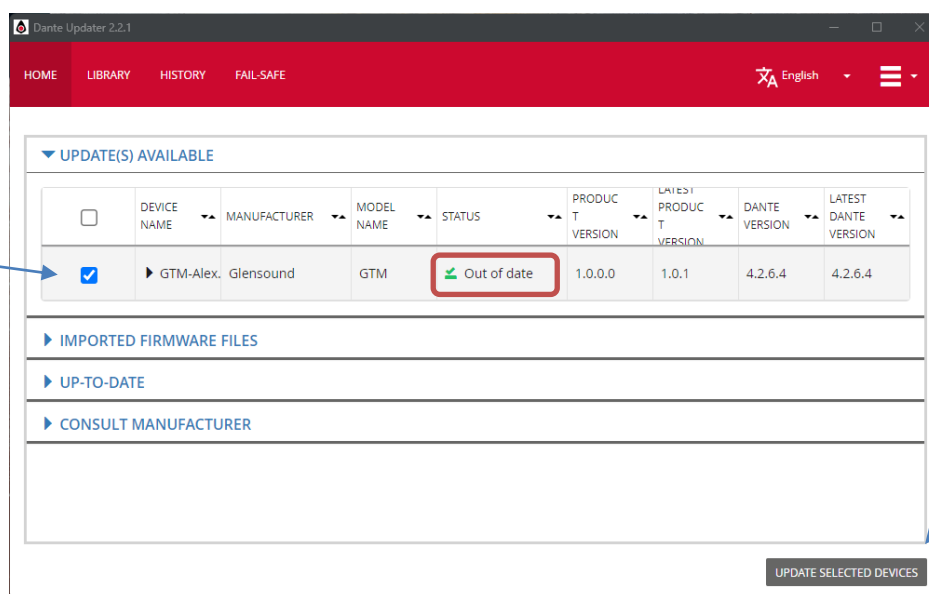

A. Tick the box to choose your unit for updating

B. Press to update device

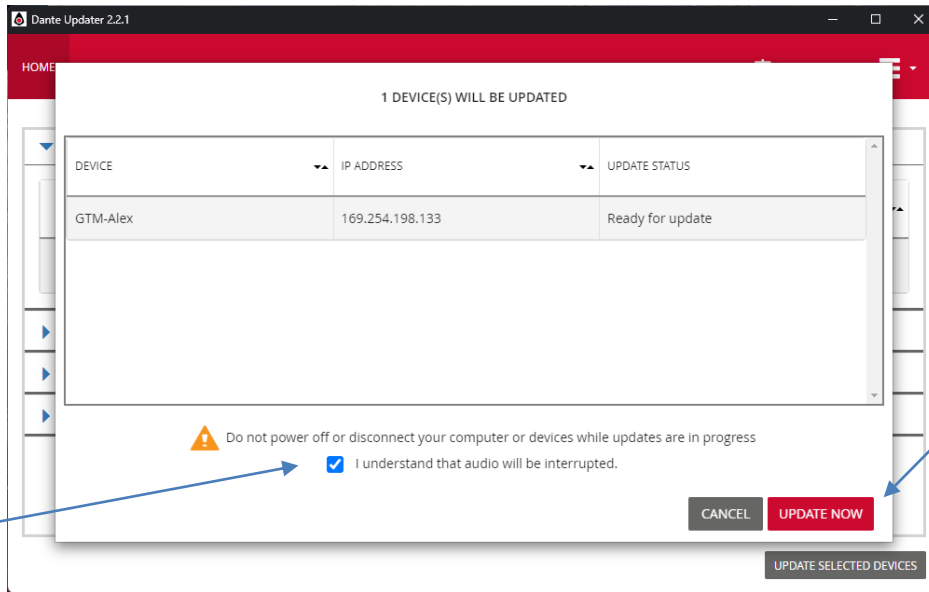

Caution! Audio will be interrupted during the device update

A. Tick box to confirm

B. Press to update device

4.

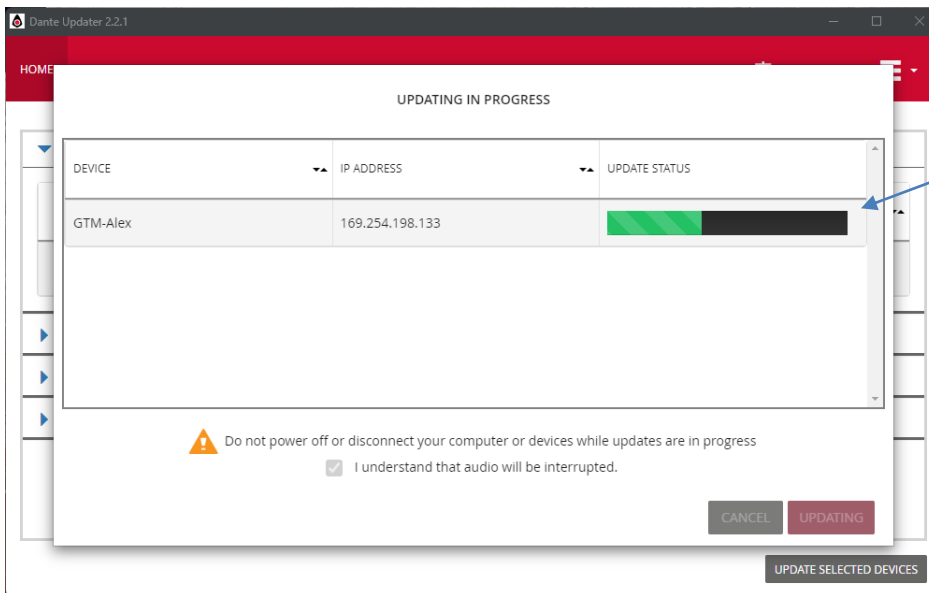

Update is in progress

5.

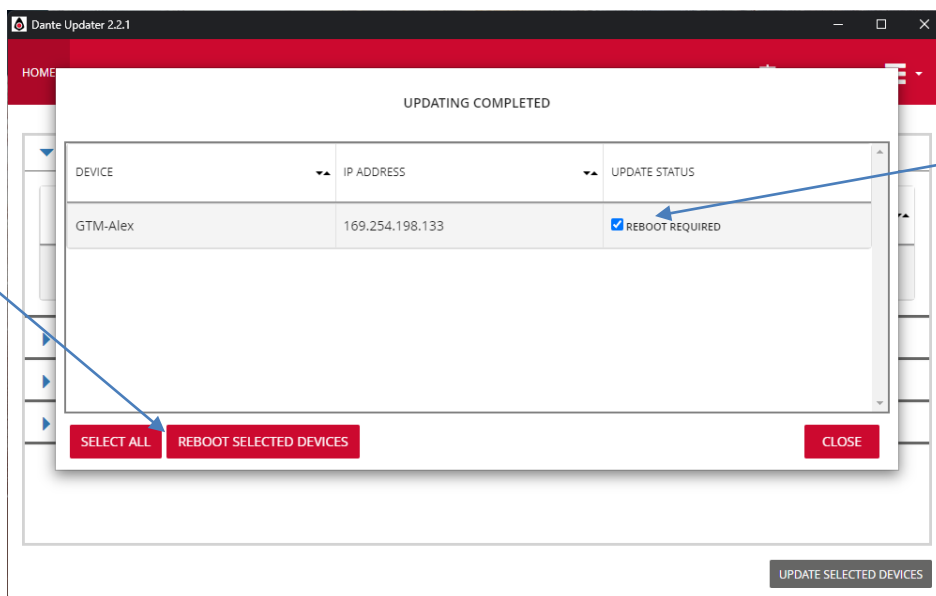

A. Update finished. Tick box to continue

B. Press to reboot device

Update finished, device will now reboot

3.

Wiring Information

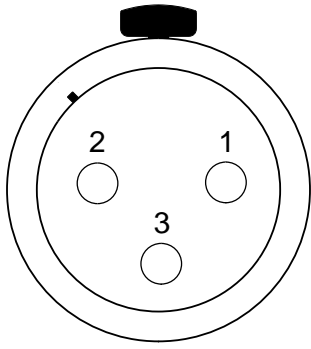

XLR SOCKET (FEMALE)

STANDARD XLR AUDIO PINOUTS:

1: Ground/ Earth

2: INPHASE/ POSITIVE/ MIC +

3: MATE/ NEGATIVE/ MIC -