

# 46-50 : 4-Zone Mixing Amplifier

482.6mm / 19"



88mm  
/ 3 1/2"  
(2U)

Cloud 46-50 front view



Cloud 46-50 rear view

## General Description

The Cloud 46-50 is a versatile, four-zone, rack-mounting (2U) audio mixing amplifier. It combines simple control of background music, microphone paging and power amplification for up to four zones in a single unit. It is suitable for use in many types of premises, such as pubs, bars, clubs, leisure and fitness centres, shops, offices, hotels, etc.

The 46-50 has six stereo line inputs and two microphone inputs; one mic input can be configured for paging purposes. Each line and mic input has its own preset sensitivity control on the rear panel, and each mic input additionally has HF/LF EQ adjustment to optimise the inputs for greatest clarity. The 46-50 has four mono zone outputs, each being driven by a 50 W (nominal rating) power amplifier stage. Pre-power stage outputs (0 dBu, unbalanced) are also provided for Zones 1 and 2. Line 6 input may be set to have priority over any other selected music source in Zone 1, to facilitate connection of a jukebox, digital sound store or similar device. The priority feature has selectable release times, to allow a smooth return to the original music source.

Any or all of the outputs may be configured as high impedance, allowing the 46-50 to drive 70/100 V-line loudspeaker systems with the addition of an optional 4-channel, internally-fitting transformer module. Alternatively, single transformers are available as standard accessories for external connection. EQ cards to suit popular installation speakers from various manufacturers may be fitted to any or all outputs. If less than four separate zones are required, the power amplifier stages for Zones 2 and/or 3 may be fed with the programme from Zone pre-amp sections 1 and/or 4 respectively, doubling the amplifier power available.

The front panel provides separate user controls for adjusting the level of each mic input, music source selection and music level, for each zone. Preset controls for HF and LF EQ adjustment of each zone output are also fitted.

The 46-50 is directly compatible with all Cloud PM Series paging microphones; alternatively, the paging mic input can be configured to suit most OEM paging systems. Zone selection for paging is via short-to-ground access connections, and the unit may be configured by internal jumper for automatic music ducking (mic-over-music priority), triggered by VOX control.

A particularly useful feature of the 46-50 is the Zone 1 Facility Port; this allows remote input plates of various types (available as standard Cloud accessories) to be connected so that mic and/or line sources - such as radio mics, DJ mixers, iPods, laptops or other audio sources - may be connected in the zone itself. This simplifies the use of an area of the premises for presentations or other special functions where portable audio sources are in use.

Music level only, or music level and source selection may be controlled remotely in any or all zones if wished, using standard Cloud RL or RSL Series remote control plates. As with all Cloud commercial audio products, a remote Music Mute facility is provided, which may be used to satisfy the requirements of the Local Fire Officer.

- Eight input (6 x line, 2 x mic) mixing amplifier for four zones
- Provides flexible music, paging and announcement facilities in each zone
- 4 x 50 W power output
- Dynamic clip limiting in power amplifier stage
- Zones 1 & 2 auxiliary line level outputs (pre-power amplifier), for connection of additional external amplifiers
- Front panel user controls for music source, music level and level of each microphone, for each zone
- Front panel preset controls for HF/LF EQ for each zone output
- Six (unbalanced) stereo line inputs with individual gain trim controls
- Two balanced mic inputs; 15V phantom power selectable on either or both
- Contact closure access port for paging zone selection
- Selectable VOX-triggered mic-over-music priority
- Sensitivity and HF/LF EQ adjustment for mic input (rear panel)
- Selectable LINE 6 priority in Zone 1, with choice of release times
- Slave mode: two power amplifier stages may be fed from a single programme source
- Zone 1 Facility Port for connection of optional LM-1 (mic/line) or DM-1 (dual mic) remote input plates
- Facility Port may also be used as additional balanced line input to Zone 1
- Optional CL-4160 4-channel 70/100V transformer can be fitted internally
- Optional CXL-40T 70/100V toroidal transformers available for per-output external installation
- Selectable 65 Hz high-pass filter per-output (for use with 70/100V line systems)
- Music Mute control input (N/O or N/C) for interface to emergency system
- Compatible with standard Cloud remote control panels: RL Series (music level) and RSL Series (music level and source selection), per-zone
- Optional EQ cards available to suit various popular installation loudspeakers may be fitted in any or all outputs
- 2U 19" rack-mounting unit
- Thermostatically-controlled fan cooling

## Block Diagram

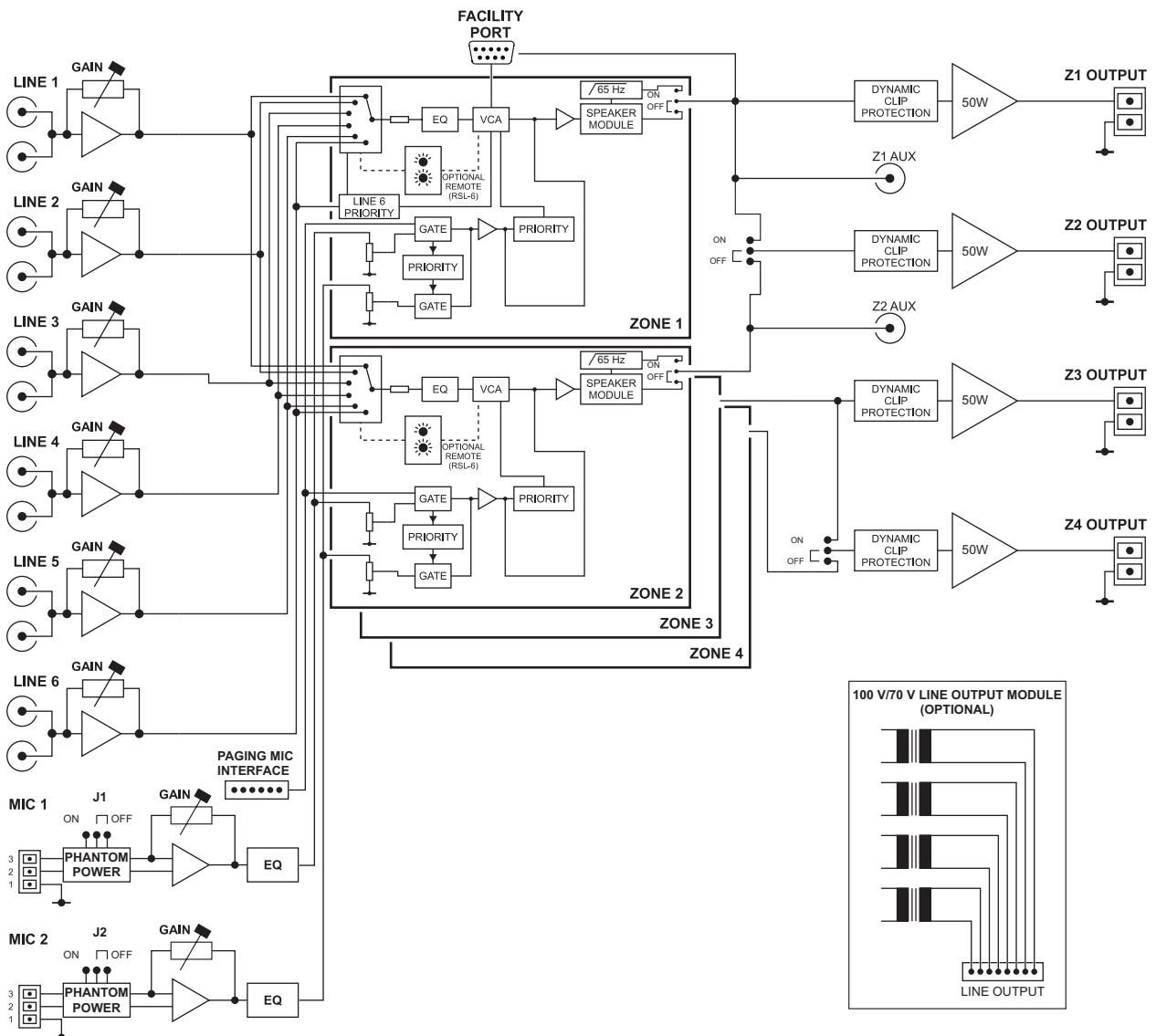

## System Example

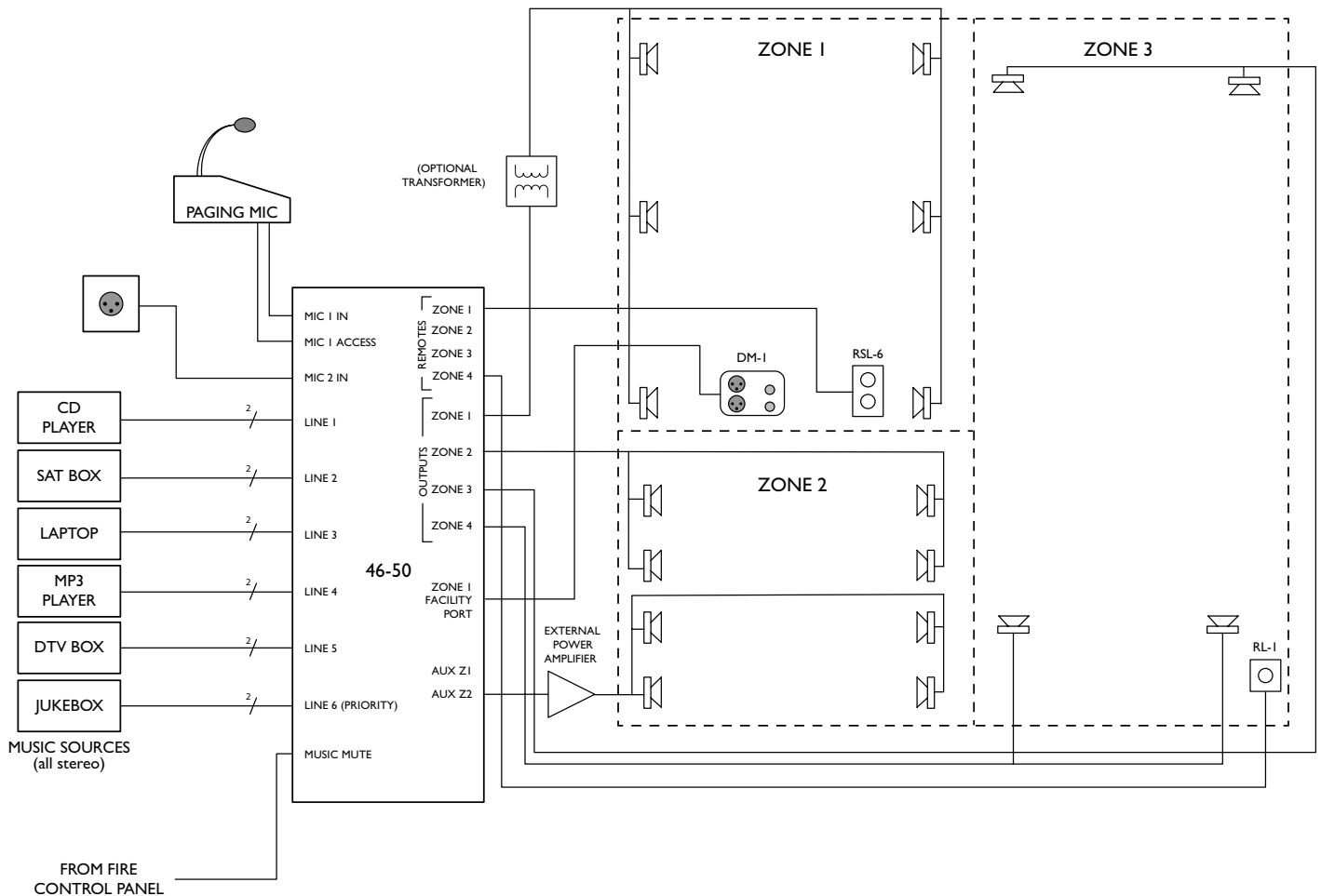

The example shows how the 46-50's various features may be used in an installation situation based on three distinct building areas.

- Six stereo music sources are connected to the line inputs. Note that the jukebox is connected to Line 6; if this input priority option is enabled, any jukebox selection will automatically be replayed through Zone 1, overriding the local selection for the duration of the track(s).
- Zone 1 has been depicted as using 70/100 V-line loudspeakers, hence the optional external transformers. In this case, these would be Cloud type CXL-40T, typically mounted on a CXL-800 rack tray. Alternatively, one of the transformers on the internally-fitted CXL-4160 module could be used.
- Zone 2 might need additional amplification, so as well as some of the loudspeakers being driven directly by Zone 2's output (using series/parallel wiring to ensure that the total load impedance remains above 4 ohms), Zone 2's Aux output is used to drive a separate external power amplifier, which in turn drives further loudspeakers.
- The example assumes that the Zone 3/Zone 4 'slave mode' is enabled; this means that Zone 4's control section will drive the power amplifier stages for both Zone 3 and Zone 4. All the loudspeakers are physically in Zone 3.
- A paging microphone may be connected to Mic 1 input; the 46-50's access port allows paging to any or all of the zones by simple contact-closure.
- Mic 2 input is wired to an XLR socket (suitable decorative plates are available as standard Cloud accessories) to allow the connection of an additional microphone which can be routed to any or all zones.
- The system also shows a Cloud RL-1 remote control plate installed in Zone 3 to allow local volume control, and an RSL-6 in Zone 1 to allow local source selection as well as volume control. Note that the RL-1 in Zone 3 is actually connected to the remote control port of Zone 4; this is because the Zone 3/Zone 4 slave mode uses Zone's 4 preamplifier channel to derive the audio feed.
- A DM-1 remote input plate is shown in Zone 1; this would be wired back to the 46-50's Zone 1 Facility Port. It would allow two microphones to be plugged in within the zone itself, and routed to the loudspeakers in the zone. The level of each mic is adjustable on the DM-1 plate itself.

## Technical Specification

Line inputs		
Frequency response	20 Hz to 20 kHz +0/-3 dB	
Distortion	<0.03%, 20 Hz to 20 kHz	
Sensitivity	195 mV (-12 dBu) to 2.0 V (+8 dBu)	
Input Gain control	20 dB range	
Input impedance	47 kohms	
Headroom	>20 dB	
Noise	-90 dB (0 dB gain, 22 Hz to 22 kHz)	
Equalisation	HF: $\pm 10$ dB @ 10 kHz    LF: $\pm 10$ dB @ 50 Hz	
Microphone input		
Frequency response	100 Hz -3 dB (fixed filter) to 20 kHz $\pm 0.5$ dB	
Distortion	<0.05%, 20 Hz to 20 kHz	
Gain range	10 dB to 50 dB	
Common Mode Rejection	>70 dB @ 1 kHz	
Input Impedance	>2 kohms (balanced)	
Headroom	>20 dB	
Noise	-128 dB EIN 22 Hz - 22 kHz (R <sub>s</sub> = 150 ohms)	
Equalisation	HF: $\pm 10$ dB @ 5 kHz    LF: $\pm 10$ dB @ 100 Hz	
Outputs		
Low Impedance Outputs	4 ohm load	50 W
	8 ohm load	35 W
Auxiliary Outputs (Zones 1 & 2)	0 dBu (unbalanced)	
100V-line Output*	100V balanced – 250 ohm minimum load	
70V-line Output*	70V balanced – 125 ohm minimum load	
Amplifier Protection	Dynamic Clip Protection, VI Limiting, DC Offset, thermal & switch-on delay	
Cooling	Variable speed DC fan	
General		
Power input	230V $\pm 5\%$ (115V $\pm 5\%$ available)	
Fuse rating	230V:T3.15AH; 115V:T6.3AH	
Fuse type	20 mm x 5 mm 250V	
Dimensions	Net	482.6 mm x 88 mm (2U) x 382 mm / 19" x 3.5" x 15"
	Shipping (Gross)	610 mm x 200 mm x 460 mm / 24" x 8" x 18"
Weights	Net	7.65 kg / 17 lbs
	Shipping (Gross)	10.2 kg / 23 lbs

\* with optional CL-4160 module fitted internally

## Architect's and Engineer's Specification

The mixing amplifier shall have four mono output channels; each channel shall be capable of driving 50 watts into a 4 ohm load. An optional module shall be available to allow any or all channels of the mixing amplifier to drive 70V or 100V-line loudspeaker distribution systems. The module shall be retrofittable and be contained within the chassis of the mixing amplifier. It shall be possible to configure the four zones in two pairs, or one pair plus two independent zones, so that two zone outputs are controlled by a single set of controls and process the same programme selection. Two of the zones shall be equipped with unbalanced line level outputs suitable for driving external amplifiers; use of these outputs shall not interrupt the unit's normal operation.

The mixing amplifier shall be equipped with six unbalanced stereo music inputs on rear panel phono sockets (RCA jacks) and two electronically balanced microphone inputs on multi-pin screwterminal connectors. One microphone input shall be configured to operate with paging microphones. Each music input shall have an input gain trim control with a range of 20 dB; two-band equalisation adjustment shall be provided for each microphone input; these controls shall not be user-accessible. Phantom power shall be available at the microphone inputs when selected by internal jumper. A gain control of the preset type shall be provided for each microphone input; these shall have a range of 40 dB, and not be accessible to the user.

Each of the output zones shall have dedicated front panel controls for selection of music source and music level and the levels of each microphone input. The front panel shall also have controls of the preset type for two-band equalisation adjustment in each zone. A tamper-proof cover shall be provided to make the equalisation controls inaccessible in normal operation.

A control input shall be provided to activate one microphone input by external contact closure, and route its signal to any or all outputs. It shall be possible to configure the mixing amplifier such that this microphone signal automatically reduces the music signal by approximately 30 dB while it is present. It shall also be possible to configure the mixing amplifier so that i) one line input will automatically override all others in one zone, even if unselected; it shall be possible to set the time over which the selected source is restored after the override input ceases to one of three values of up to 12 seconds; ii) one microphone input shall have priority of the other should both be active simultaneously.

Optional remote control panels shall be available to permit control of i) music level in any zone; ii) music source selection and music level in any zone; it shall be possible to retrofit these to the mixing amplifier at any time. The remote control panels shall connect via a rear panel multipin connector. It shall be possible to disable either the front panel music level or the music level and music source selection controls by settings which are not accessible to the user. An external control input shall be provided to allow muting of the music source by a fire alarm or other external emergency system via isolated, 'voltage-free' contacts, and this input shall be configurable to respond to either a short or open external circuit.

One zone of the mixing amplifier shall be equipped with a multifunction control connector. A range of external active input plates shall be available which may be wired to this connector, enabling external mic or line level signals to be routed to the zone from a remote location. The multi-pin connector shall permit the connection of a balanced audio source, and also provide DC power for the remote plates. It shall be possible to configure the mixing amplifier so that a signal at this input has priority over the other microphone inputs.

The mixing amplifier shall accept a range of plug-in equaliser cards to permit use with compatible loudspeakers. It shall be possible to fit these in any or all of the outputs.

The mixing amplifier shall be built in a 2U steel chassis for mounting in a standard 19" rack. The mixer will be fitted with a front-panel power switch with internal indication. Two mains supply variants shall be available: 230 V or 115 V. Mains supply shall be connected via a detachable IEC cable.

The mixing amplifier shall be the Cloud 46-50; the optional remote control panels shall be the Cloud RL-1 (music level only) and the Cloud RSL-6 (music level and source selection) and the optional remote input plates shall be the Cloud LM-1 (line and microphone level inputs plus control of music source selection) and the Cloud DM-1 (two microphone inputs). The optional internal 70/100 V transformer module shall be the Cloud CL-4160.