



FLUORESCENT SCRIPT LIGHTS - DIMMABLE

- 51-956 CANFORD SCRIPT LIGHT Fluorescent, 600mm, black, 50Hz, dimmable, low voltage control
- 51-957 CANFORD SCRIPT LIGHT Fluorescent, 900mm, black, 50Hz, dimmable, low voltage control
- 51-958 CANFORD SCRIPT LIGHT Fluorescent, 1200mm, black, 50Hz, dimmable, low voltage control
- 51-986 CANFORD SCRIPT LIGHT Fluorescent, 600mm, white, 50Hz, dimmable, low voltage control
- 51-987 CANFORD SCRIPT LIGHT Fluorescent, 900mm, white, 50Hz, dimmable, low voltage control
- 51-988 CANFORD SCRIPT LIGHT Fluorescent, 1200mm, white, 50Hz, dimmable, low voltage control

DESCRIPTION

Canford script lights are constructed from elegant aluminium extrusions with fully adjustable shutters and are finished in a black eggshell stove enamel. The script light provides a narrow 'curtain' of light directed at the desired work surface.

They have an integral electronic ballast and Northlight tubes, (near illuminant D65), with a colour temperature of approximately 6500 K.

The cases are available in three sizes to take fluorescent tubes:

600mm long	20 watt
900mm long	30 watt
1200mm long	36 watt

Spare lamps available, (see next page).

Script lights are for 220/240 volt operation.

The dimmable fluorescent script light is designed to be used with a 10V low voltage control unit stock code 51-959, (not included).

CONDITIONS OF USE

Note For normal indoor use only. Some luminaires may have more than 1 ballast.

As the control circuit is not segregated in the ballast from the mains, the DC cable must be insulated as for mains cable. As the DC current will be less than 1A however, the conductor cross sectional area can be small, e.g. 0.5mm² – but **must be** a mains rated cable.

To avoid mains pick up the DC and mains cables should be segregated, (e.g. by using separate conduits), unless the length of run is less than 5m.

Ensure that the control unit is correctly fitted into an earthed steel back box, (stock code 49-601).

INSTALLATION INSTRUCTIONS

Only appropriately qualified staff should carry out this installation.

TURN THE ELECTRICITY SUPPLY OFF AT THE MAINS BEFORE INSTALLING OR MAINTAINING THIS LUMINAIRE!

Following unpacking and inspection for damage in transit, the lamp should be removed by easing back one holder until the pins become visible - and then lifting it out of the lamp-holder fittings. External wiring should be connected through the rubber grommet to the terminal block.

WARNING - THIS EQUIPMENT MUST BE EARTHED

Connect **Live** wire to the terminal marked **'L'**

Connect **Neutral** wire to the terminal marked **'N'**

Connect **Earth** wire to the terminal marked **'E'**

(Note: Un-insulated protective earth wires are sleeved with green/yellow insulating sleeve.)

NOTE

In the UK the completed installation must comply with "Regulations for electrical installations", current edition, as published by the Institution of Electrical Engineers.

Care should be taken when connecting the mains, ensuring the mains connection is only made to the correct terminals.



FLUORESCENT SCRIPT LIGHTS - DIMMABLE

CONTROL UNIT TERMINALS

To wire the ivory finish low voltage 10V controller, (51-959), to the script light follow Figure 1 below.

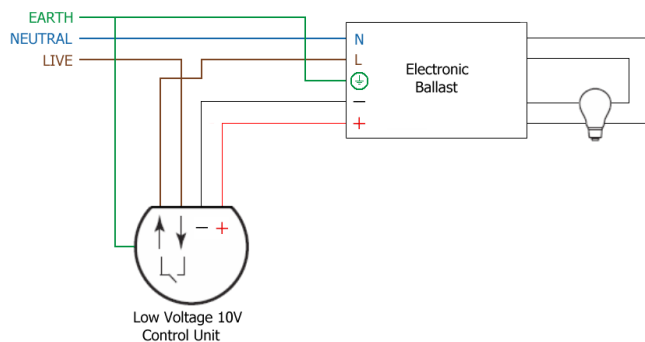

Figure 1 Low Voltage Control Unit set up

There are 4 screw terminals, two for the DC and also two for the LIVE IN and switched LIVE OUT feed. Refer to the control unit instructions.

All terminals accommodate one 2.5mm² solid or stranded cable, or two 1.5mm² solid or stranded mains rated cables.

For the control of more than one lamp and further wiring information please read the installation instructions supplied with the control unit itself.

A 46mm minimum depth single gang steel flush mount back-box will be required for mounting the control unit, (stock code 49-601).

WARNINGS

Observe polarity of DC connections.

Ensure that the steel back-box and electronic ballast circuit is earthed as per Figure 1.

The mains switch may be a separate item, chosen to match existing décor. In this case the LIVE IN and switched LIVE OUT terminals of the control unit should be ignored.

MAINTENANCE

- 1 Ensure a copy of these instructions is presented to the responsible authority for maintenance.
- 2 Replace lamps only with suitable types as described below.

51-854 CANFORD SCRIPT LIGHT Fluorescent, spare lamp 600mm, 230V, 20 watt

51-855 CANFORD SCRIPT LIGHT Fluorescent, spare lamp 900mm, 230V, 30 watt

51-857 CANFORD SCRIPT LIGHT Fluorescent, spare lamp 1200mm, 230V, 36 watt

It is important that only the stated replacement lamps are used.

ACCESSORIES

51-959 CANFORD SCRIPT LIGHT Fluorescent, Control unit for dimmable versions

49-601 STEEL FLUSH BOX 1 gang, 47mm deep



FLUORESCENT SCRIPT LIGHTS - DIMMABLE

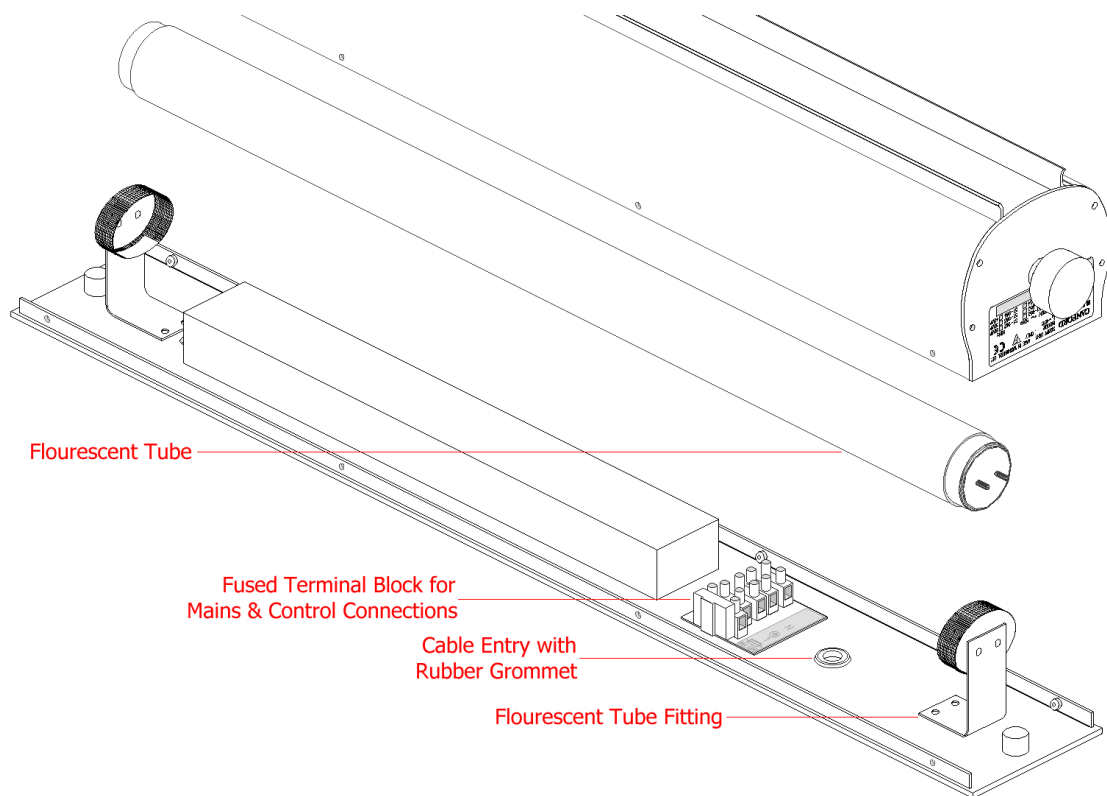

Figure 2 Script Light Exploded Diagram

TECHNICAL SPECIFICATION

EQUIPMENT TYPE - Fixed class Luminaire, for wall mounted, internal use.

Conforming Standards:	BS4533 Luminaries.	
BS EN 60065	Specification of safety requirements for mains operated electronic and related equipment approved for household and similar general use.	
BS EN 60598-1	Luminaries, general requirements and testing.	
EC Compliance:	EMC Directive 89/336/EEC	
Low Voltage Directives:	73/23/EEC	
	93/68/EEC	
Rated Voltage:	220/240V 50Hz	51-956, 51-957 and 51-958
Rated Wattage:	20Watts	51-956
	30Watts	51-957
	40Watts	51-958
Dimensions: (with knobs fitted)	600mm type	725 x 100 x 90mm (L x W x H)
	900mm type	1025 x 100 x 90mm (L x W x H)
	1200mm type	1325 x 100 x 90mm (L x W x H)