



Technical Data Sheet

LED SIGNAL LIGHT POWER SUPPLY

51-310 LED SIGNAL LIGHT POWER SUPPLY

INTRODUCTION

The range of Canford LED Signal Lights, 51-302/303/305/306/309/312/313/315/316/319, require a DC voltage of 12 to 24 volts. The brightness and on-off switching of the light is controlled on by a separate input pin.

This mains powered free-standing unit provides this DC power and allows the remote switching and control of two independent Canford LED Signal Lights. It maintains electrical isolation of the Signal Light connections from the mains. Control is implemented using either a closing contact or by applying 5-50 volts DC. (The format of the control signals required will be familiar to users of the Canford Opto Switcher 42-682.)

Mains input connector is IEC (CEE22) 3 pole with a 20mm fuse on the input line. The two control inputs each use a 3 pin female XLR panel connector. The two output connectors each use a 4 pin XLR female panel connector.

Facilities of PSU / requirements of LED Signal Light

The Canford LED Signal Light requires a DC voltage of 12 to 24 volts at a current of 150mA at 12 volts and 80mA at 24 volts. This unit provides two independent 20 volt supplies on two 4 pin XLR female connectors. Pin 1 is 0v and pin 3 is +20 volts. The two input/output sets are independent and isolated from one another. So 0v on Input A / Output A is isolated from 0v on Input B / Output B. Each output has a

300mA current limit, so a short on the output connections will shut down that output. Power is restored by switching the mains input power off and on.

If the control input pin on the LED Signal Light is open circuit, then the light runs at maximum brightness. The brightness is reduced by shunting the control pin to 0v with a resistance. The light is off if the control pin is shorted to 0v. The control output pin of the LED Signal Light PSU, pin 2 on the 4 pin XLR output connector, is switched to ground when an input OFF signal is received at the 3 pin XLR input connector and to open circuit when an input ON signal is received at the 3 pin XLR input connector.

SWITCHING METHOD 1

Apply a closing contact across pins 1 and 3 of the control XLR. If logic or transistorised switching is intended, the following information may be helpful:

- (1) Pin 1 open circuit voltage is approximately +5 volts DC (load switch off) with respect to pin 3
- (2) Pin 1 when forced low (<1v) requires a current sink capability from the switching element of 1mA.

SWITCHING METHOD 2

Apply between +5 to +50 volts DC to pin 2 relative to pin 3 of the control XLR.



WARNING: THE CASE IS CONNECTED TO MAINS EARTH - ALWAYS USE MAINS EARTH

WIRING DETAILS

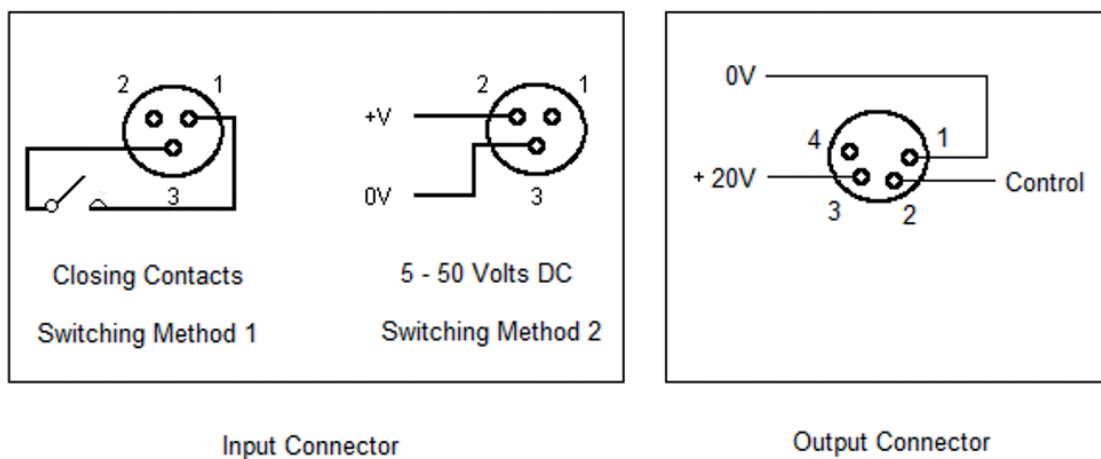

TECHNICAL SPECIFICATION

Mains input:	230 VAC @ 0.1A
Fuse:	20mm; 0.25A(T) HRC (Stock code: 42-282)
Contact closure output sink requirement:	5 VDC @ < 1mA (close to switch load on)
DC input:	5-50 VDC @ < 2 mA (pin 2 positive; apply voltage to switch load on)
Isolation between Input A and Input B:	> 50 V
Size:	Standard extruded case; 210mm L x 110mm W x 48mm H
Weight:	800g
Mating connector stock codes:	
IEC input	42-154
4 pin XLR Power output plug	41-042
3 pin XLR Control input plug	41-032

Ensure that the case receives adequate ventilation.