

CLS2 Installation Handbook

Handbook Contents

- Safety
- Introduction
- Block diagram
- Overview
- Connections
- Installation
- Troubleshooting
- Accessories
- Technical Specifications
- Warranty
- Declaration Of Conformity

Box Contents

- 1 x CLS2
- 1 x 'Installation Handbook'
- 1 x Deaf logo
- 1 x P-clip, nut & washer





This symbol is used to alert the user to important operating or maintenance instructions.



The Lightning bolt triangle is used to alert the user to the risk of electric shock.

SAFETY

1. It is important to read these instructions, and to follow them.
2. Keep this instruction manual in an accessible place.
3. Clean only with a dry cloth. Cleaning fluids may affect the equipment.
4. Do not install this equipment near any heat sources such as radiators, heating vents or other apparatus that produces heat.
5.  **WARNING – THIS APPARATUS MUST BE EARTHED / GROUNDED.**
6. Only power cords with the correct power connector may be used to maintain safety. Cables incorporating the UK 13A fused plug, Schuko with earthing contacts and UL approved “grounding type” are acceptable. These must be plugged into power outlets which provide a protective earth.
7. Refer all servicing to qualified personnel. Servicing is required when the apparatus has been damaged in any way, such as a power supply cord or plug is damaged, liquid has been spilled or objects have fallen into the apparatus, the apparatus has been exposed to any rain or moisture, does not operate normally or has been dropped.
8.  **WARNING – To reduce the risk of fire or electric shock, do not expose this apparatus to rain or moisture. The apparatus shall not be exposed to dripping or splashing and no objects filled with liquids, such as vases, shall be placed on the apparatus.**



CAUTION
RISK OF ELECTRIC SHOCK
DO NOT OPEN

TO PREVENT ELECTRIC SHOCK DO NOT REMOVE THE COVER. THERE ARE NO USER SERVICEABLE PARTS INSIDE. REFER SERVICING TO QUALIFIED PERSONNEL.

INTRODUCTION

The CLS2 Induction loop driver has been designed as a high quality amplifier for use in community centres, board rooms, churches, interview rooms, meeting rooms and classrooms. Depending on a number of factors regarding the installation of the loop and the set-up of the amplifier the CLS2 can provide compliance with IEC60118-4 for areas $>400\text{m}^2$.

The unit is designed for wall or panel installation (or optional insertion into a 1U rack space), with a hinged and detachable lid which is secured by two PH2 screws. All connections are made via screw terminal blocks within the amplifier case and cables are brought into the unit through 20mm 'knock-out' holes on the top, bottom or back face of the amplifier. All adjustments are made within the amplifier case reducing the likelihood of tampering after commissioning.

Ease of installation and use have been major factors in the design, combined with optimized performance, and the freedom from R.F.I. generation.

The CLS2 has four audio inputs. A 100V line / speaker line, a balanced line, a balanced microphone, and one which can be configured as balanced line or balanced microphone.

Two additional inputs are also provided for connection to various alarm or alert signals. Each one when operated attenuates the audio inputs and produces a unique tone on the loop to identify the source in question.

Block Diagram

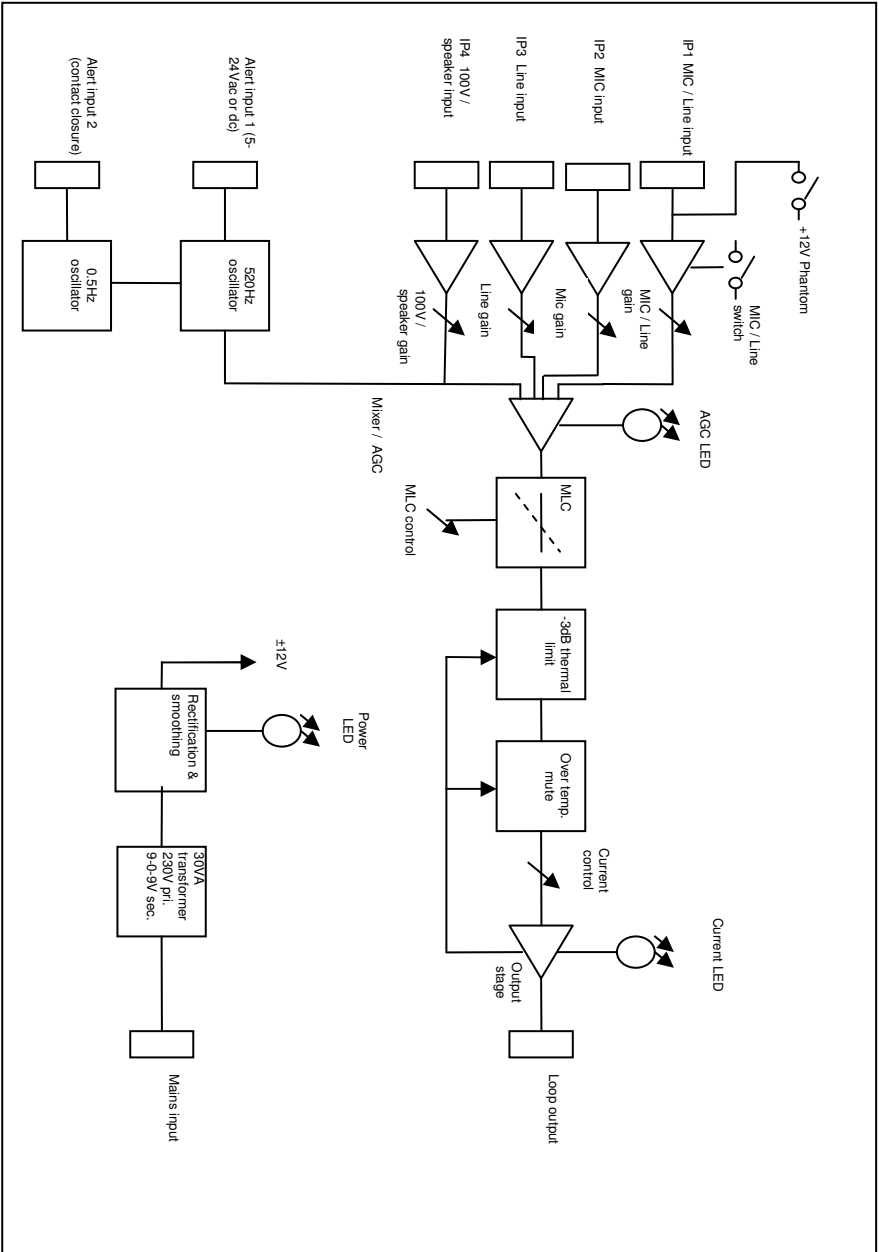

OVERVIEW

Mounting and Cable entry (shown with lid removed)

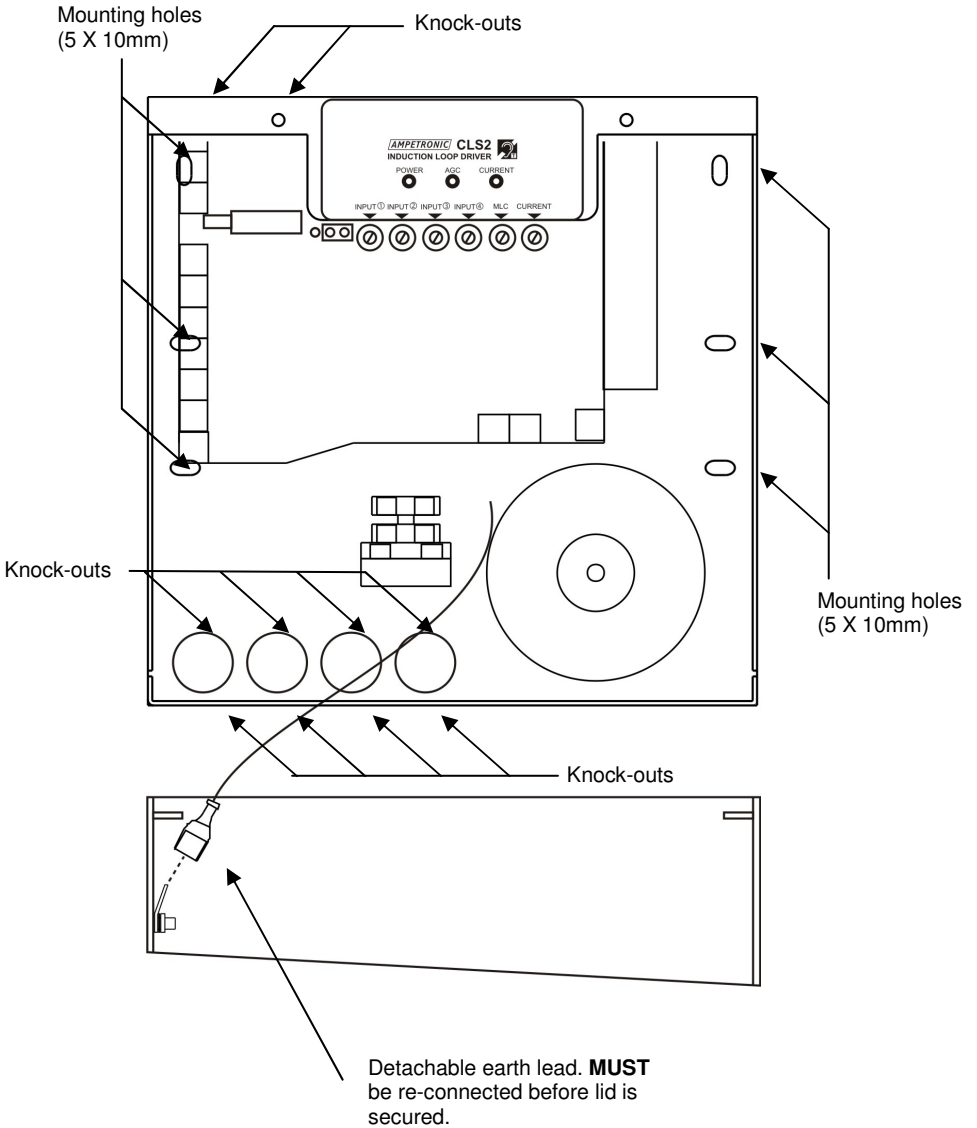

Controls and Indication

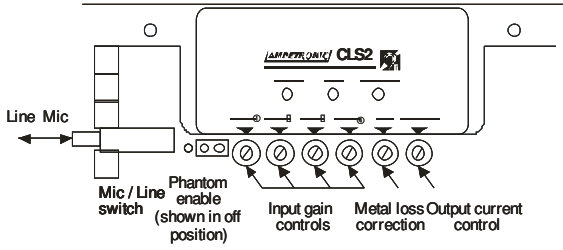

Connections (For wiring details see next section)

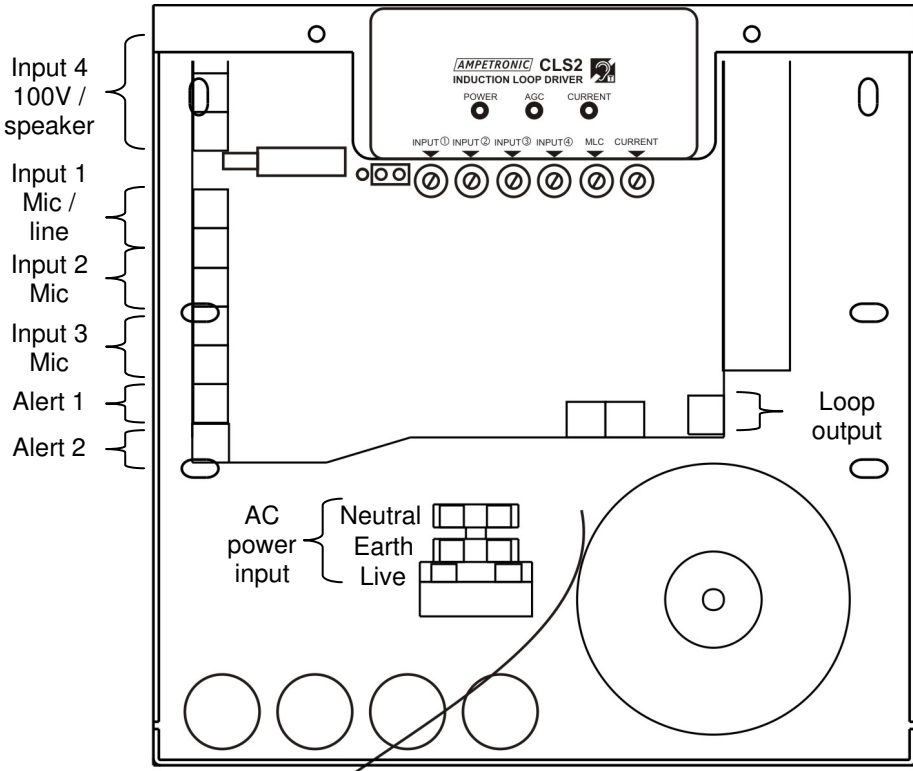

CONNECTIONS

All connections are made using screw terminals which accept up to 2.5mm² (14 AWG) wire. To avoid a single strand of wire shorting to other conductive parts wires should be striped no more than 6mm.

Signal Inputs:

Phantom global to IP1 & IP2

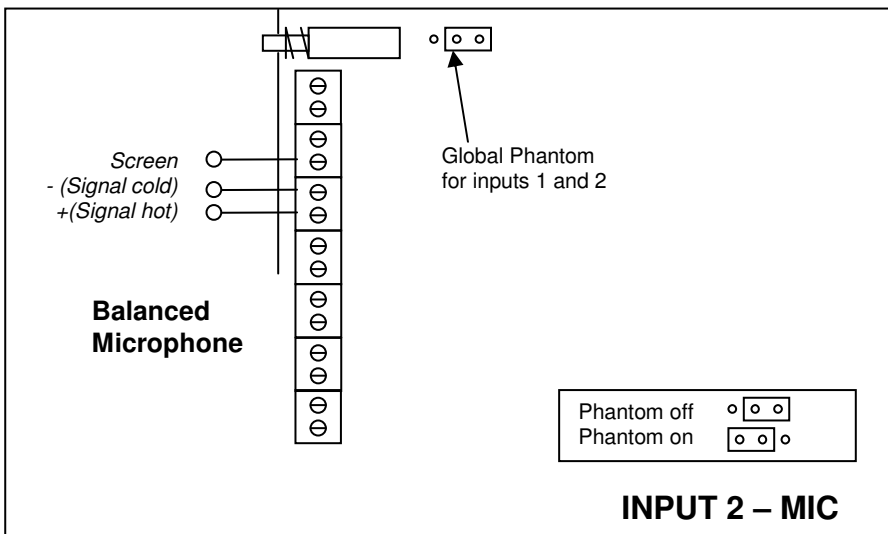
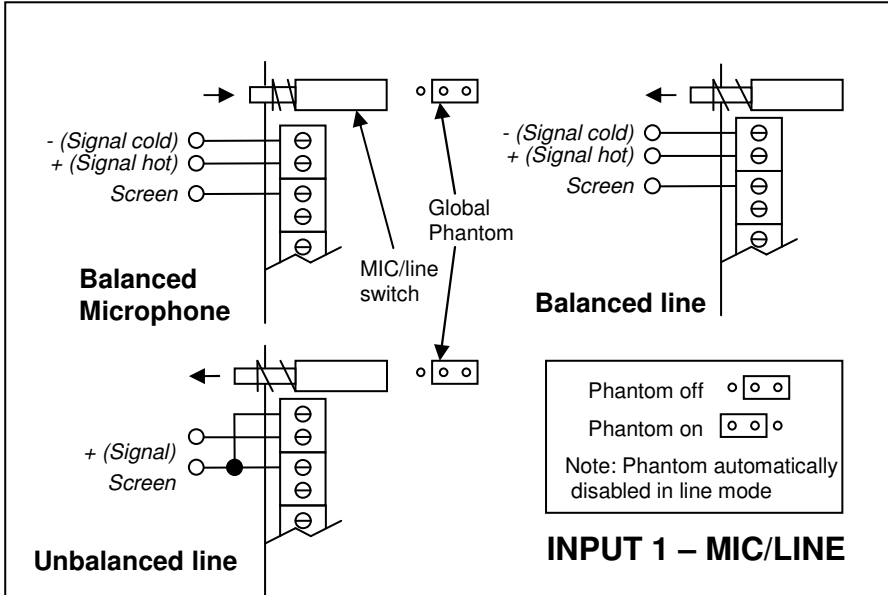

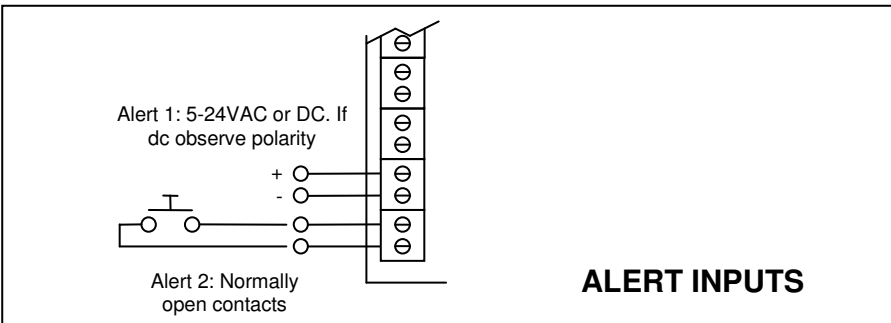
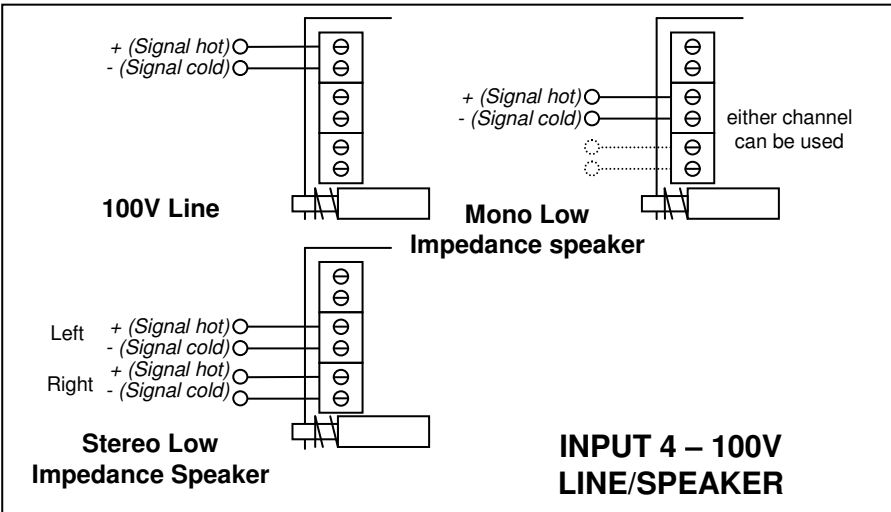
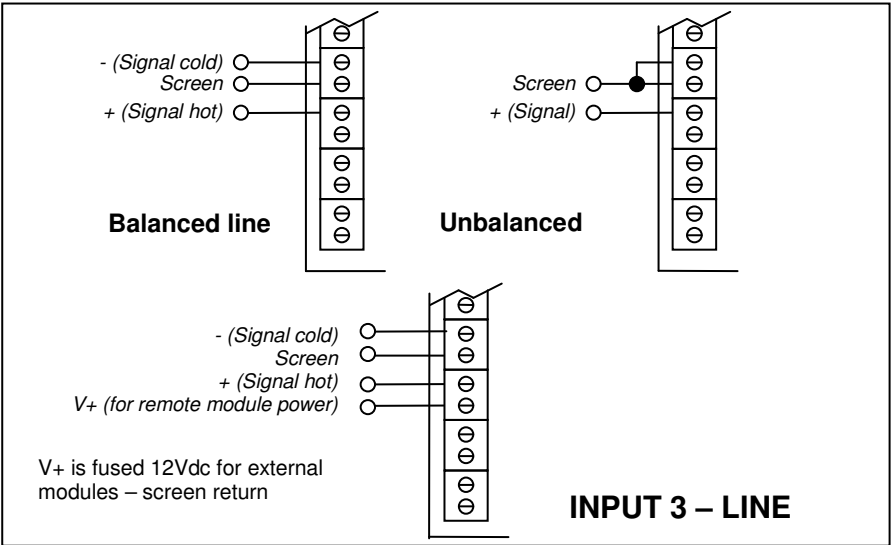

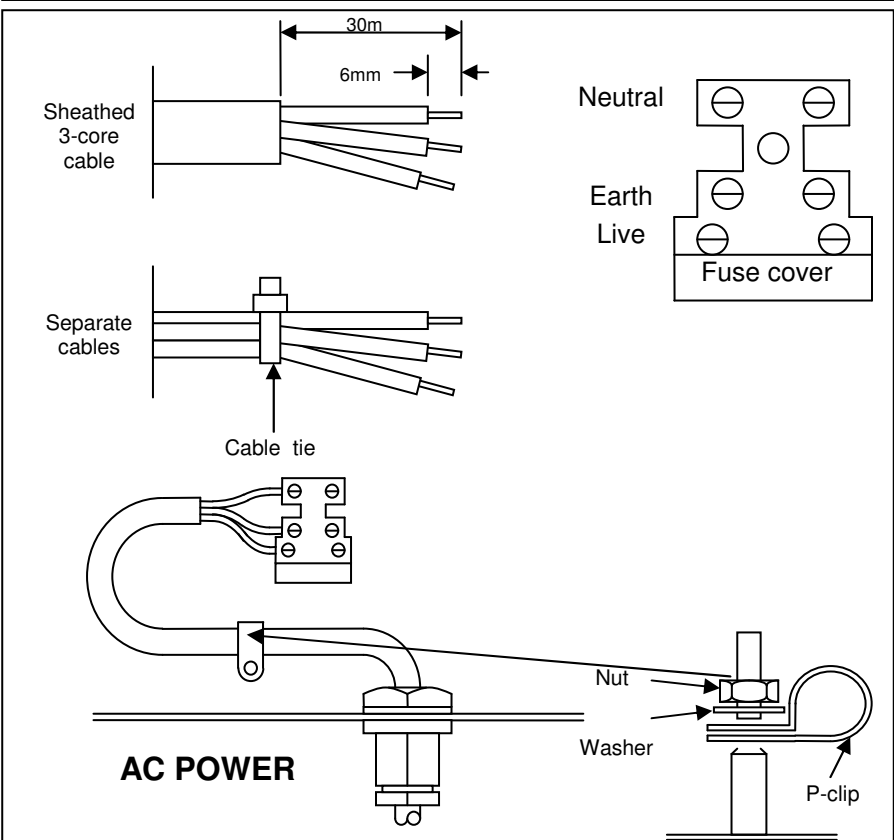
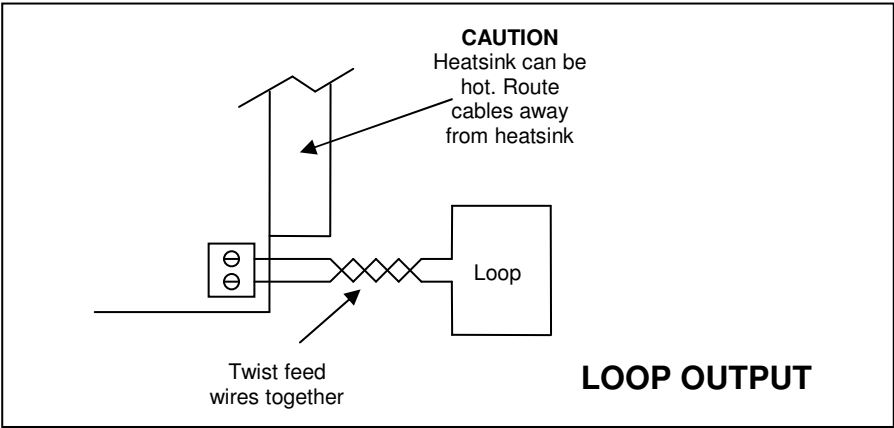

INSTALLATION

System Requirements

The induction loop cable should be installed as detailed in the 'Designing Induction Loops' handbook (available on request at www.ampetronic.com), or as per specific design instructions provided by Ampetronic.

Tools and Equipment

A magnetic field strength meter (e.g. Ampetronic FSM) or a loop receiver (e.g. Ampetronic ILR3 or ILR3+) is vital to check that the loop system is providing the desired level of performance.

As well as tools for securing the unit to the wall, a large flat bladed screwdriver and hammer are required to remove the knock-outs.

A small flat bladed screwdriver is necessary to adjust the controls and secure cables into the screw terminals.

A PH2 driver is required to open and close the lid.

Location

The unit is designed for wall or panel installation (or optional insertion into a 1U rack space), with a hinged and detachable lid which is secured by two Phillips No 2 screws. The unit may also be used free standing.



The location must provide adequate ventilation for the unit. If the unit is installed in an enclosed environment, sufficient airflow into the enclosure must be provided through vents, fans or other means.

Contact Ampetronic for advice on cooling requirements for your installation.

Once the location is decided remove the hinged lid by first unplugging the earth wire then lifting the lid out of the hinge arrangement.

Use the base section to mark the wall for drilling.

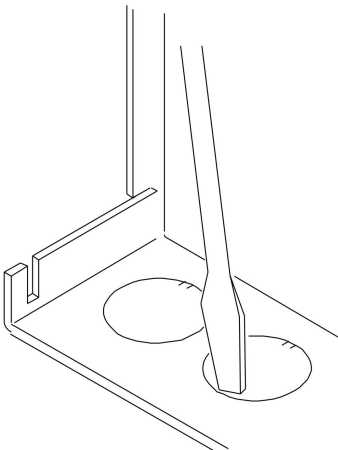

Remove the required knock-outs for cable entry.

Knock-outs are removed from the inside of the unit as shown by placing a screwdriver on the edge of the knock-out (opposite the 'tie point') and giving a single sharp blow to the end of the screwdriver with a hammer or mallet.

Care must be taken during removal so that internal parts are not damaged.

It is recommended that the AC power feed use a single knock-out close to the AC power terminal block and be routed away from other cables. The loop cable should also be kept separate and use

its own knock-out. However if all inputs are to be used it is possible to route line level signals with the loop cable for a short distance.



Once knock-outs are removed fit suitable cable glands with strain relief or conduit fittings to protect the cable and maintain safety. If the AC power is fed to the unit using a cable which is accessible to the user use the P-clip provided for additional strain relief as well as a suitable cable gland. see **Connections** drawing.

Any knock-outs left open must be blanked off with a suitable plug. Cable glands and conduit fittings are available at most electrical suppliers.



The CLS2 is classed as permanently connected apparatus and as such shall be installed in accordance with relevant building and wiring regulations.

Connection and Set-up

It is advised that the loop system is initially set up using a local audio source such as a CD player, which is not connected into any other system. This avoids the complication of ground loops and feedback etc, whilst the unit is set up.



The following procedure assumes cables have already been installed to the site where the unit will be mounted and that the **AC power feed is isolated**.

1. Mount the unit in its intended position.
2. Route cables / conduits to appropriate knock-outs or through the back panel. The black heatsink bar can reach 90°C in normal operation and may affect cables which are touching it. Cables must be routed away from this area.
3. Turn all controls fully anti-clockwise.
4. Connect the loop feed cable into the loop terminals. The feed cable should be tightly twisted. The 'Designing Induction Loops' handbook contains more details on loop and feed cables. The correct design and positioning of the actual loop is vital for satisfactory system performance. If in doubt consult Ampetronic for advice.
5. Connect the signal inputs appropriately:



Microphones (balanced only): Suitable dynamic or condenser microphones. Select phantom power as required. Connect to appropriate terminals of INPUT 1 or INPUT 2 (with Mic/line selector switch in the Mic. position) see **Connections** drawing.

Line level signals (balanced or unbalanced): From other audio equipment such as PA system, mixing desk or CD player. If no microphone is used connect to appropriate terminals of INPUT 1 (with selector switch in the Line position) see **Connections** drawing.

Line level signals (balanced mono or unbalanced mono and stereo): From other audio equipment such as PA system, mixing desk or CD player. Connect to appropriate terminals of INPUT 3 see **Connections** drawing.

 **100V line / low impedance speaker:** Connect to the appropriate terminals of INPUT 4 see **Connections** drawing. This input may have a hazardous voltage on its terminals and must only be connected by a suitably qualified person.

Alert/alarm signals: From fire alarms, doorbell or telephone systems see **Connections** drawing.

6. Connect AC power to the mains terminal block. Cables entering the terminal block must be secured together such that in the event one terminal loosening the conductor cannot come out of the terminal block and become unsafe. If multi cored cable is used the outer sheath should be stripped back no more than 30mm to serve the same purpose. See **Connections** drawing.



If stranded cables are used strip back no more than 6mm. see **Connections** drawing. See also points 5, 6 and 7 in **Safety** section.

Ensure all relevant tests of AC supply have been carried out before turning supply on.

7. Turn on AC power feed. The POWER and AGC LEDs will illuminate. If the LEDs fail to illuminate consult the **Troubleshooting** section. The AGC LED will go out after a few seconds.
8. Select one input and apply a suitable audio signal (ideally the FSM test signal CD applied via a CD player to INPUT 1 or 3, with no connection to the other inputs). Turn the associated input control clockwise until the AGC LED illuminates.
9. Turn the CURRENT control clockwise until the CURRENT LED begins to illuminate. If high frequency oscillation or low frequency hum is experienced, consult the **Troubleshooting** section.
10. The loop system should now be providing a magnetic field inside the area of the loop – use a field strength meter or loop receiver to examine its performance with respect to:
 - a. Magnetic field strength. This may vary across the coverage due to layout, metal loss and loop current.
 - b. Frequency response. Metal losses tend to increase with frequency, and may require the adjustment of the MLC control.

As a result of this analysis, adjust the CURRENT and set the MLC. Ideally a field strength meter should be used to ensure adequate magnetic field strength (0.4A/m rms with a sinewave signal) and a level

frequency response ($\pm 3\text{dB}$ ref. 1kHz between 100Hz and 5kHz) to satisfy IEC60118-4. Once the CURRENT and MLC controls have been adjusted to the correct level they should **NOT** need re-adjusting.

NOTE: If the magnetic field strength, or frequency response varies significantly between the edges and the centre of a perimeter loop this may indicate significant metal loss. If the standard cannot be met a redesign of the loop will be required.

11. If not already done so, steps can now be taken to integrate the CLS2 into a PA / mixer arrangement following standard audio techniques. If any unusual effects are experienced refer to the **Troubleshooting** section.

Note: Ideally, each input signal level should be set to just illuminate the AGC LED with the quietest level of input likely to be used. This will maximize the dynamic range of the system and ensure satisfactory performance.

12. Repeat the above procedure for each input used. When adjusting each input, make sure the signals are removed from the other inputs. This ensures that all signals are set to equivalent loudness and drive the AGC properly.
13. Finally refit the lid and earth wire. Secure with the screws provided.



The earth wire **MUST** be reconnected to maintain safety

TROUBLESHOOTING

POWER LED not illuminated

Check fuse continuity. A 20mm fuse is incorporated into the mains terminal block. Test the continuity of the fuse using a multimeter. A spare fuse is provided in the fuse holder



Any replacement fuse **MUST** be of the same rating and type as printed on the inner label of the unit.

AGC LED not illuminating

Check input connections.

Ensure that the appropriate front panel control (INPUT1, INPUT2, INPUT3 or INPUT 4) is turned up. Check there is sufficient signal level for the required input.

CURRENT LED not illuminating

Check the AGC LED is illuminating.

Check that the CURRENT control is turned up sufficiently.

Ensure the POWER LED is illuminated.

Check that the loop cable is connected & terminated correctly.

Check the loop is not open circuit, short circuit, or connected to earth (see instability or high frequency noise section of **Troubleshooting**)

The unit could be overheating (loop current is not delivered if the internal heatsink reaches a predetermined level). To establish if this is the case turn the unit off and allow to cool down before turning on.

Ensure that the unit is installed in a location with sufficient ventilation.

Low magnetic field strength

Due to insufficient current or excessive metal loss.

May require a special loop design to achieve acceptable performance, contact Ampetronic for advice.

Instability or high frequency noise

1. It is possible for the loop cable to be grounded under fault conditions, resulting in instability which may sound like high frequency noise, buzz or whistling.

This fault is easy to determine. Simply disconnect the loop cable from the amplifier and test with a resistance meter between either of the loop wires and a good earth point such as a metal radiator. There should be an infinitely high reading i.e. no connection at all. Any reading indicates a failure of the loop cable insulation and you will need to either repair or replace the loop cable.

2. Instability can be caused by using poor quality signal cables, long unbalanced (2-wire) signal runs to the inputs, or by running input cables in close proximity with the loop wire over an appreciable distance. Loop amplifiers are capable of delivering high currents at audio frequencies. If the loop cable is run close to sensitive signal cables it may be possible to induce a signal back into the input of the amplifier causing feedback. Cable runs and loop wires should be kept well apart from each other. To avoid interference maintain a separation of at least 300mm.
3. Instability can cause the amplifier to run hot and may result in an overheat condition (see **CURRENT LED not illuminating** section).

Interference

1. Background magnetic field signals or interference may be present in any location and may not be anything to do with the loop system. Monitor this with a loop receiver (such as an ILR3, ILR3+ or Field strength meter). If the interference is still present with the loop system switched off, then you need to locate and eliminate the source of the interference before switching the loop system back on

2. Magnetic fields can induce currents into any low impedance electrical path or loop. Audio or video systems with multiple earths may experience pick up of the loop signal. Check entire sound system for evidence of loop signal, and trace source of pick up.
3. Under certain circumstances, the loop signal may appear as jagged lines or hum bars on a CCTV picture. This could be due to running CCTV (low impedance unbalanced 2-wire circuit) cables in close proximity to the loop cable. Separate the loop cables to reduce the effect.
4. Remote (and apparently unconnected) PA systems can sometimes pick up loop signals. This is usually because the loop cable becomes damaged (see point 1 of **Instability**) or induces signals into the remote system through long unbalanced cables. Always run long audio signal cables as 3-wire balanced circuits and keep away from loop cables.
5. See also point 1 of **Instability**

ACCESSORIES

Details of all products and services provided by Ampetronic can be found at www.ampetronic.com

TECHNICAL SPECIFICATIONS

INPUTS

INPUT 1 (MIC/Line)

Input Impedance: 10k Ω per side
Sensitivity: -73/-31dBu
Overload: -37/+5dBu

INPUT 2 (MIC)

Input Impedance: 10k Ω per side
Sensitivity: -73dBu
Overload: -37dBu

INPUT 3 (Line)

Input Impedance: 1M Ω per side
Sensitivity: -33dBu
Overload: +3dBu
V+: 12Vdc 100mA max

INPUT 4 (100V/speaker)

Input Impedance: 120k Ω /7.8k Ω
Sensitivity: +15/-9dBu
Overload: >+47/>+27dBu

Alert 1 520Hz tone

Input range: 5-24V ac or dc (if dc observe polarity)

Alert 2 pulsed 520Hz tone

For connection to a pair of contacts. Closed energises alert.

AC Power

Voltage: 230V
Frequency: 45-65Hz
Power consumption: 30W
Fuse: T250mA L fitted into terminal block.

SIGNAL PROCESSING

AGC (Automatic Gain control)

Dynamic range: 36dB
Output level: -6dBu (\pm 1dB)

Attack: 3.8ms

Decay: 1.7s

MLC (Metal loss correction)

Frequency response adjustment
From flat to +3dB/octave centred around 1kHz

OUTPUTS

Loop Output

Max. Voltage: 9Vpk, 6.4Vrms
Max. Current: 7A_{pk}, 5A_{rms}
Short term peak current: >10A
Continuous max. current: 2.3A_{rms}
Frequency response: 80Hz – 6.3kHz (-3dB)
Distortion: <0.5% @2.3A_{rms}
Min loop resistance: 0.2 Ω
Max loop impedance: 1.3 Ω (@1.6kHz)

PROTECTION

Current Limit

Peak current limited to approx. 14A

Thermal protection

The output is muted if the internal heatsink reaches 90°C. Approaching this figure the output is attenuated to a maximum of 3dB to prevent nuisance tripping.

PHYSICAL

Dimensions: 200x200x44mm

Weight: 1.8kg

Operating temperature: -10 to 40°C

IP rating: IP20

WARRANTY

This product carries a five year parts and labour warranty from date of shipment from Ampetronic. To qualify for the five year warranty, the product must be registered at www.ampetronic.com (products/warranty), without which the warranty will be valid for two years only.

The warranty could be invalidated if the instructions in this handbook are not followed correctly, or if the unit is misused in any way.

DECLARATION OF CONFORMITY

Manufacturer: Ampetronic Ltd.,

Northern Road,
Newark,
Nottinghamshire.
NG24 2ET.
United Kingdom.

Declares that the product:

Description: Induction Loop Driver

Type name: CLS2

Conforms to the following Directive(s) and Norm(s):

Directive 2004/108/EC

EMC: EN55103-1 : 2009 Emission
EN55103-2 : 2009 Immunity

Directive 2006/95/EC

Safety: EN60065 : 2002

Date: January 2011
J.R. Pieters
Managing Director
Ampetronic Ltd.